

Potensic ATOM 2

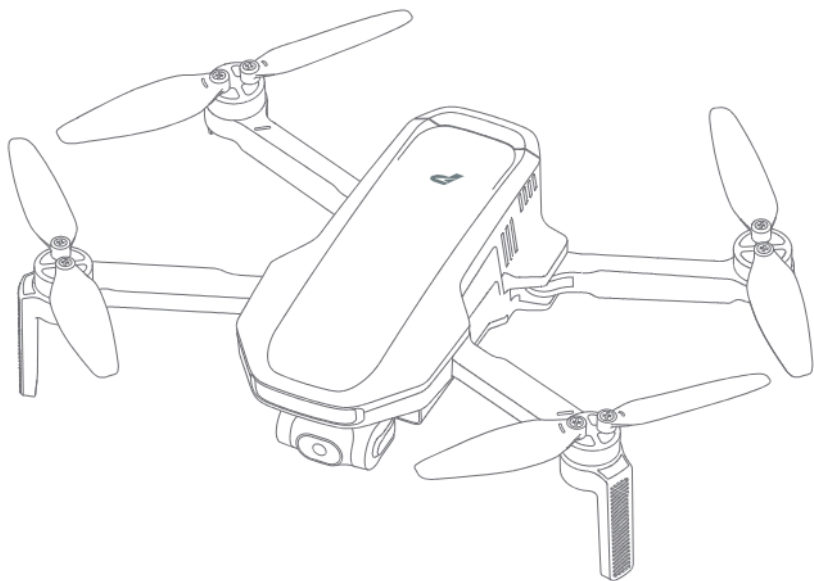

DANGER
Only suitable
for ages 16+



User Manual

V08. 25. 12

Email: support@potensic.com
Email: support.uk@potensic.com
Email: support.de@potensic.com

Email: support.fr@potensic.com
Email: support.it@potensic.com
Email: support.es@potensic.com

Tel: +1 833 549 7772
Web: <https://www.potensic.com>
FB: www.facebook.com/Potensic

Contents

1. Disclaimer & Precautions	02	6. Remote Controller	22
1.1 Disclaimer	02	6.1 Overview	22
1.2 Safety & Precautions	02	6.2 Control Stick Mode	22
1.3 Warning & Prompts	02	6.3 Function	23
		6.4 Optimal Transmission Zone	26
		6.5 Remote Controller Calibration	27
2. Reading Tips	03	7. Potensic Eve App	28
2.1 Legend	03	7.1 Home Screen	28
2.2 Suggestions of Use	03	7.2 Flight Interface	29
2.3 Tutorial Video/Download App	03	7.3 Settings	34
2.4 Registration&Help	04		
2.5 Technical Terms	04		
3. Overview	05	8. Flight	36
3.1 Introduction	05	8.1 Requirements of Flight Environment	36
3.2 Drone Diagram	05	8.2 Pre-Flight Checklist	37
3.3 Remote Controller Diagram	06	8.3 GEO Zone	37
		8.4 Connection	38
4. Using for the First Time	07	8.5 Flight Mode	38
4.1 Preparing the Drone	07	8.6 Beginner Mode	38
4.2 Preparing the Remote Controller	07	8.7 Takeoff/Landing/Hovering	39
4.3 Charging/Startup and Shutdown	08	8.8 Return to Home (RTH)	41
4.4 Activating the Drone	09	8.9 Intelligent Flight Mode	44
4.5 Firmware Update	09		
		9. Appendix	52
5. Drone	10	9.1 Specification&Parameters	52
5.1 Positioning	10	9.2 Post-Flight Checklist	56
5.2 Downward Vision System	10	9.3 Maintenance Instructions	56
5.3 Drone Status Indicator	11	9.4 Troubleshooting	56
5.4 Smart Battery	12	9.5 Risk and Warnings	57
5.5 Propellers	15	9.6 Disposal	57
5.6 Gimbal and Camera	16	9.7 CO Certification	57
5.7 Flight Record Playback	19	9.8 Risk categories and assessment	58
5.8 SmartTransfer	19	9.9 Drone Pilot Information Notice	60
5.9 Compass Calibration	20	9.10 EU Compliance Notice	61

1. Disclaimer & Precautions

» 1.1 Disclaimer

Drones are products with potential dangers and relatively complex operations. Prior to usage, it is crucial to thoroughly read the complete User Manual to grasp basic knowledge and become familiar with the drone's functions. For the initial use of ATOM 2, it is recommended to operate it in GNSS mode in a spacious outdoor area to acquaint yourself with its functions.

Strictly adhere to the Manual's operational instructions and precautions to ensure safe and correct usage.

Users below the age of 16 should be supervised by an adult, and the product should be kept out of reach of children.

The Company disclaims responsibility and does not provide warranty services for any direct or indirect losses (including property loss and personal injury) resulting from the user's failure to follow the Manual's safety guidelines.

Avoid dismantling any part of the product except for propellers or modifying it without official guidance; users will be accountable for any consequences arising from such violations.

For assistance with usage, operation, and maintenance issues, feel free to contact our local dealer or the Company.

The drone's onboard software has undergone rigorous security certification and incorporates advanced encryption and anti-tamper mechanisms to ensure its code cannot be altered by unauthorized users. These security measures can instantly detect and prevent any illegal modifications to the software, effectively safeguarding the drone's flight control and data collection functions from malicious software, viruses, or hacker attacks.

The copyright and ownership of this document belong to Shenzhen Potensic Intelligent Co., Ltd. (hereinafter referred to as "Potensic"), and the information is subject to change without notice. For the latest updates, please visit <https://www.potensic.com>.

» 1.2 Safety & Precautions

Keep Away from Obstacles and Crowds

To ensure the safety of both the user and those around, please keep the product away from crowded areas, high-rise buildings, and high-voltage cables. Additionally, refrain from using it in severe weather conditions such as strong winds, heavy rain, and thunderstorms. This precaution is necessary as the product may exhibit unpredictable flight speeds, status fluctuations, and potential hazards.

Keep Off Moisture

To prevent anomalies or damage caused by humidity affecting precise electronic components and mechanical parts inside the product, please ensure it is kept away from moisture.

Safe Operation

When operating the drone, the likelihood of unforeseen risks rises when users are fatigued, in poor mental condition, or lack experience. To ensure safety, it is essential to refit or repair the product using original parts. Operate the product strictly within specified limits, and be sure to adhere to local safety regulations.

Keep Away from High-speed Revolving Parts

While the product's propellers are spinning at a high speed, keep it away from crowds and animals to prevent scratches or disturbances. Avoid touching the spinning propellers with your hands.

Keep Away from Heat Source

To prevent anomalies, deformation, and potential damage, keep the product away from heat and high-temperature exposure. This precaution is especially crucial as the product comprises metal, fiber, plastic, and electronic elements.

» 1.3 Warning & Prompts

01. Keep the package and manual in a secure place as they contain important information.
02. Users are responsible for ensuring that the use of this drone does not cause harm to the person or property of others.

03. Our company and dealers are not liable for losses and personal injuries resulting from improper use or operation.
04. Users must strictly follow the steps outlined in the user manual to install and test the drone. During flight, maintain a minimum distance of 1 to 2 meters from users or other individuals to prevent the drone from colliding with human bodies, causing injury.
05. The product should be assembled by an adult. Users aged below 16 should not handle the product alone. The battery should be charged under the supervision of an adult and should be kept away from flammable materials during the charging process.
06. The product contains small parts. Please place them out of reach of children to prevent accidental ingestion.
07. Do not operate the product over roads or standing water to avoid accidents.
08. It is forbidden to dismantle or refit the product, except for the propellers, as doing so may lead to malfunctions in the drone.
09. Please recharge the intelligent battery with a USB charger that conforms to FCC/CE standards.
10. The remote controller has a built-in 3.6 V lithium battery which needs no replacement.
11. Do not short-circuit or squeeze the battery to avoid explosion.
12. Do not place the battery in hot place (in fire or near electric heater).
13. Keep a safe distance from the high-speed revolving propellers; avoid using the product in crowds to prevent scratches or injuries.
14. Do not use the product in places with strong magnetic field, such as near high-voltage cable, buildings that contain metals, automobiles and trains; otherwise, the connection stability can be compromised.
15. Please make sure to thoroughly understand local laws and regulations to avoid any unauthorized use of the drone.
16. To comply with the requirements of the aeronautical radio magnetic environment, during the period of radio control orders issued by the relevant national authorities within the specified regions, the use of remote controller should be suspended as instructed.
17. Please refrain from flying at low altitudes over water surfaces.
18. Please stay away from airports, flight paths, and other restricted areas.

2. Reading Tips

» 2.1 Legend

 Prohibited

 Important

 Operation & use prompts

 Technical terms and reference information

» 2.2 Suggestions of Use

1. It is advisable to watch the tutorial video and **Quick Start Guide** before referring to the **Manual**.
2. Be sure to read the **Disclaimer & Precautions** section first when consulting the **Manual**.

» 2.3 Tutorial Video/Download App

Scan the QR code on the right and you can:

1. Download Potensic Eve App.
2. Watch the tutorial videos.
3. Access the latest User Manual.
4. Learn about the frequently asked questions (FAQ).



 • Potensic Eve App supports iOS 13.0 and above, as well as Android 7.0 and above.



» 2.4 Registration & Help

It's required to set up an account when using the App for the first time to have better user experience. We guarantee never to collect any user information without authorization.

Registration Procedures

1. Enter your email address on the registration page.
2. Obtain the verification code and enter it, then read and agree to the User Agreement and Privacy Policy.
3. Set a password to complete the registration.

Once registration is successful, you will be automatically logged in.

-  During registration, please ensure your mobile device is connected to the internet.
- If you do not receive the verification code during registration, please check your spam folder, as the verification email may have been mistakenly marked as spam.
-  Without registering and logging into a Potensic account, you will be unable to activate the drone and are restricted to 3 trial flights. It is recommended that you register and log in to your account to activate the drone.

Help

Thanks for purchasing Potensic ATOM 2. Before using the drone for the first time, we recommend that you read the user manual carefully.

Please contact our support team at support@potensic.com if you encounter any problem or issue with the drone.

» 2.5 Technical Terms

IMU	IMU (inertial measurement unit), the most important core sensor of the drone.
TOF (Time of Flight)	TOF (time of flight), the period from transmission and receiving of detection infrared signal, in order to determine the target distance.
Downward Vision System	The sensor system, which lies at the bottom of the drone and consists of camera and TOF module.
Vision Positioning	High-accuracy positioning, which is realized through Downward Vision System.
Compass	Geomagnetic sensor, which enables the drone to identify the direction.
Barometer	Atmospheric pressure sensor, which enables the drone to determine the altitude through atmospheric pressure.
Lock/unlock	Refers to the transition of the drone's motors from a stationary state to idle rotation.
Idling	Once unlocked, the motor will start spinning at a fixed speed, but it can't provide sufficient lifting force for the drone to take off.
Auto return	The drone will return to HOME point automatically based on GNSS positioning.
Drone head	Position of the drone camera.
Throttle control stick	Ascend or descend the drone.
Pitch control stick	Fly the drone forward or backward.
Roll control stick	Fly the drone leftward or rightward.
Yaw control stick	Enables the drone to rotate clockwise or anticlockwise.

3. Overview

This chapter introduces the functional characteristics of ATOM 2, as well as the diagrams of the drone and the remote controller.

» 3.1 Introduction

ATOM 2 features foldable arms for convenient portability, with a lightweight body weighing only 245 g. The drone possesses a Vision Positioning System, which allows for precise hovering in low-altitude indoor and outdoor environments. Equipped with a GNSS sensor, the drone enables positioning and automatic return. The camera utilizes a 1/2-inch Sony CMOS image sensor, capable of capturing high-definition 4K/30 fps video and 48MP photos. The camera is mounted on a 3-axis gimbal, which allows the camera to acquire stable footages while operating the drone.

ATOM 2's remote controller utilizes the PixSync 4.0 digital transmission technology, achieving a maximum communication distance of up to 10 km and 1080p video transmission in ideal conditions. The controller features a retractable and foldable design, providing a placement for your mobile device when unfolded. When connected to the controller via a USB cable, you can operate and configure your drone through the App, as well as view high-definition video transmission. The built-in lithium battery in the remote controller has a maximum working time of approximately 4 hours.

ATOM 2 utilizes proprietary SurgeFly flight control technology, achieving a maximum flight speed of 16 m/s (52 ft/s) and a maximum flight time of approximately 32 minutes, with resistance against wind up to Level 5.

- ⚠ Test conditions of the max. flight time: at an ambient temperature of approximately 25°C in a windless environment, flying forward at a constant speed of 5 m/s, switched to 1080p/24 fps video recording mode (without video recording operation during flight) from 100% battery charge until 0%.
- Power consumption will increase considerably when the drone is returning against the wind. If you receive a prompt of encountering strong wind from the App, please make sure to lower the flight altitude and return in time to ensure safety of the drone.

» 3.2 Drone Diagram

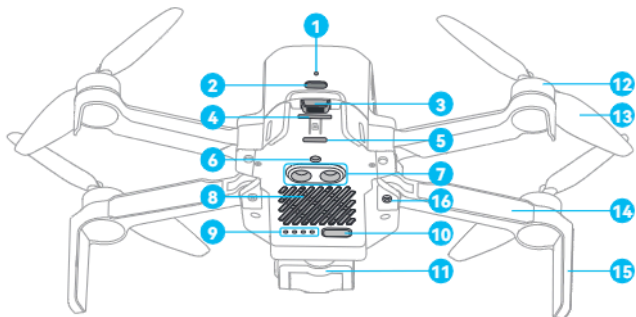

- | | | |
|----------------------------|------------------------------|--------------------|
| 1. Charging indicator | 7. TOF module | 13. Propeller |
| 2. USB-C charging port | 8. Bottom cooling hole | 14. Arm |
| 3. Battery buckle | 9. Power indicator | 15. Antenna tripod |
| 4. microSD card slot | 10. Power/pairing button | 16. Arm shaft |
| 5. Tail indicator | 11. 3-axis gimbal and camera | |
| 6. Monocular visual module | 12. Brushless motor | |

» 3.3 Remote Controller Diagram

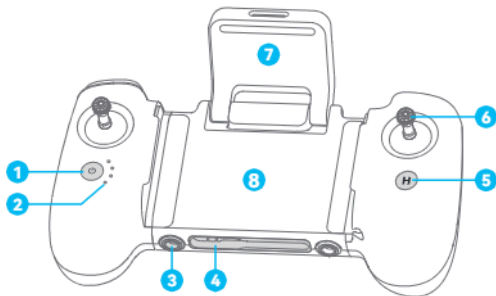

1. Power Button

Press once to check the current battery level. Press and hold to power the remote controller on or off.

2. Power Indicator

Displays the current battery level or status of the remote controller.

3. 1/4 Nut Mounting Slot

For attaching a remote controller strap (*sold separately).

4. USB-C Connecting Port

For connecting the remote controller.

5. Return to Home (RTH) Button

Press once to make the drone brake and hover from auto-flight modes. Press and hold to initiate RTH. Press again to cancel RTH.

6. Control Sticks

Use the control sticks to control the drone movements. Set the control stick mode in Potensic Eve App by entering Settings > Control > Remote Controller Settings > Control Stick Mode.

7. Foldable Directional Antenna

Transmits control and video wireless signals to the drone.

8. Mobile Device Holder

For mounting the mobile device securely on the remote controller.

9. USB-C Charging Port

For charging the remote controller.

10. Right Dial

For digital zoom control.

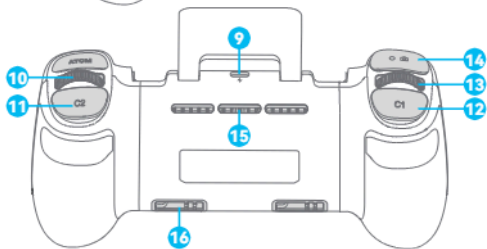

11. Customizable C2 Button

Press once to switch the speed mode (Video/Normal/Sport). Press twice to set the Cruise Control (enable/disable/update). Press C2 and Left Dial to adjust the White Balance. Press C2 and Right Dial to adjust the EM. Set the function in Potensic Eve App by entering Settings > Control > Remote Control Settings > Button Customization.

12. Customizable C1 Button

Press once to switch the camera tilt angle (0°/-90°). Press twice to switch the camera mode (auto/manual). Press C1 and Left Dial to adjust the shutter speed. Press C1 and Right Dial to adjust the ISO. Set the function in Potensic Eve App by entering Settings > Control > Remote Control Settings > Button Customization.

13. Left Dial

Control the tilt of the camera.

14. Shutter/Record Button

Press once to take a photo or start/stop recording. Press and hold to switch between photo/video.

15. Cooling Holes

16. Control Stick Storage Slot

For storing the control sticks.

4. Using for the First Time

» 4.1 Preparing the Drone

The product is delivered under folded status. Please unfold it as follows:

1. Remove the gimbal protector.
2. Unfold the front arm before the rear arm.
3. Unfold the propeller blades.



» 4.2 Preparing the Remote Controller

Mount the mobile device and the control sticks

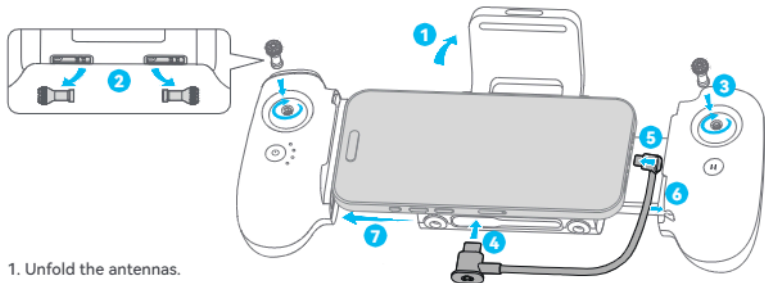

1. Unfold the antennas.
2. Remove the control sticks from the storage slots.
3. Mount the control sticks on the remote controller.
4. Connect the adapter cable with the remote controller logo with the remote controller.
5. Connect the other end of the cable with your mobile device.
6. Push the cable into the slot inside the right handle of the remote controller.
7. Pull open the remote controller with both hands and secure your mobile device in place.
8. Preparation completed.

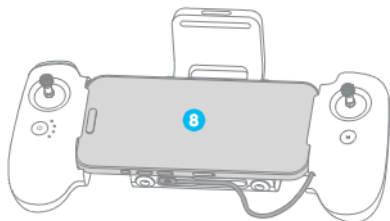

- ⚠ • The remote controller adapter cable is directional; do not swap the ends of the cable.
- Do not insert the USB-C end of the remote controller adapter cable into the remote controller's USB-C charging port, as this may cause a short circuit.
- When connecting to an Android phone, if the system prompts for a USB connection mode, please select "Data Transfer". Other options may cause the connection to fail.

» 4.3 Charging/Startup and Shutdown

Before the first flight, it is essential to wake up the battery; otherwise the drone wouldn't start. Connect the USB-C charging port of battery and a USB charger to the AC power supply to finish single charging (USB charger is not included in the package. User can use a charger that conforms to FCC/CE specification to charge the battery). The red indicator will stay on during charging, and turn off automatically after charging is done. User can charge the battery with the Parallel Charging Hub if Fly More Combo is purchased. For more details, please refer to the user manual of Parallel Charging Hub. The Parallel Charging Hub can also charge the remote controller.

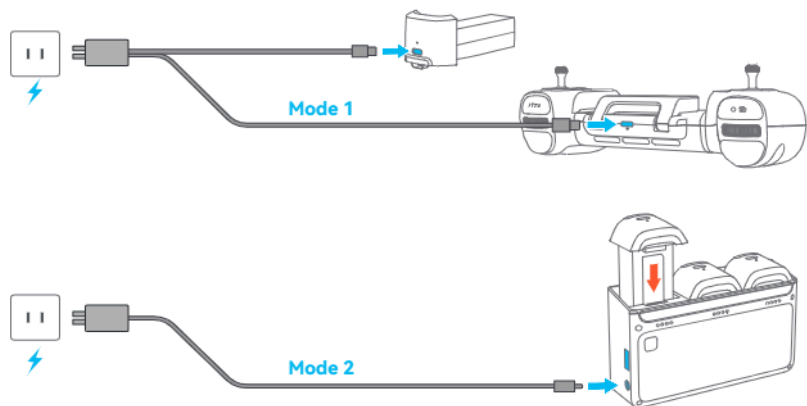

- The shortest charging period is approx. 1 h 25 min through the USB-C charging port. Make sure your charger supports 5 V/3 A output in order to achieve this charging speed.
 - User is suggested to charge the battery through the Parallel Charging Hub, in order to charge 3 batteries quickly at the same time.
-
- ⚠ It is suggested to remove the battery from the drone to charge for safety reasons; otherwise, the drone won't power on if the battery is being charged in the drone.
 - If the charging cable is connected while the drone is on, it will power off automatically and the charging will continue.
 - The battery may become too hot after use; do not charge it until it cools down; otherwise, charging can be rejected by the smart battery.
 - Charge the battery every three months to sustain the cell's activity.
 - Please connect the original cable or any cable that supports over 3 A current to the USB-C port; otherwise, it may cause charging failure or battery damage.
 - When charging the PTD 1 Remote Controller with Integrated Screen, in order to achieve optimal charging speed, please use a USB charger that supports PD 2.0 or higher fast charging protocols, paired with the original USB-C to USB-C charging cable. Using a USB-A to USB-C charging cable may not activate the fast charging function. For more detailed information about the PTD 1 Remote Controller with Integrated Screen, please refer to the PTD 1 User Manual.

Startup

Drone: Press and hold the power button until all the power indicators turn on, then release to complete the startup.

Remote controller: Press and hold the power button until all the power indicators turn on, then release to complete the startup.

Shutdown

Drone: Press and hold the power button until all the power indicators turn off, then release to complete the shutdown.

Remote controller: Press and hold the power button until all the power indicators turn off, then release to complete the shutdown.

-
- The power buttons on the drone and remote controller are designed to prevent accidental presses. Once all the battery indicators are on, release the button promptly to avoid automatic shutdown from holding it down too long.
-

» 4.4 Activating the Drone

The drone requires activation through the Potensic Eve App before first use. Power on and connect the drone and remote controller, then open the Potensic Eve App and follow the on-screen prompts to activate the drone.

After activation, the current drone and remote controller will be bound together by default. The account used for activation will have full control over the drone.

-
- An internet connection is required for activation. An unactivated drone can only perform limited flights up to 3 times.
-

» 4.5 Firmware Update

When a new firmware update is available, use the Potensic Eve App to upgrade. After connecting the drone and the remote controller, open the Potensic Eve App. The App will automatically notify you if a new firmware update is available. It is recommended that users follow the prompts to upgrade for the best experience.

-
- Before upgrading, ensure the drone's battery level is $\geq 30\%$ and the remote controller has at least two bars of charge. If not, charge them before proceeding with the upgrade.
 - Check that the gimbal protector has been removed, and ensure there are no foreign objects around the gimbal.
 - Ensure your mobile device is connected to the internet during the upgrade; otherwise, the firmware download may fail. If your current mobile device cannot download the firmware, try using a different device or operating system.
 - During the upgrade, keep the remote controller and drone within 1 meter of each other and away from signal interference sources such as computers and routers.
 - Do not operate the drone or remote controller during the upgrade (e.g., powering off the devices or plugging/unplugging cables) unless instructed by the App. Keep the devices stationary throughout the process.
-

5. Drone

ATOM 2 consists of a flight control system, a communication system, a positioning system, a power system and a smart battery. This chapter sets down the functions of all parts of the drone.

» 5.1 Positioning

ATOM 2 adopts Potensic's new SurgeFly flight control technology, which supports the following two positioning modes:

GNSS positioning: Provide precise positioning and navigation to the drone; support precise hovering, smart flight and auto return.

Vision positioning: It can realize high-precision positioning at a low altitude based on the Downward Vision System. The vision positioning can be realized without GNSS signal, so that the product can be used indoors.

How to switch: The flight control system will switch automatically according to the environment of the drone. When GNSS signals are weak and the downward vision system is unavailable, the drone will switch to Attitude Mode (ATTI). In this mode, the drone will be unable to maintain a stable hover, requiring the user to manually maneuver the control sticks to land the drone in a safe location as quickly as possible to avoid accidents. During the descent, closely monitor the drone's attitude, speed, and altitude to ensure a safe landing. To minimize the risk of entering Attitude Mode and causing flight accidents, avoid flying in areas with poor GNSS signals or confined spaces.

- ⚠️ • In Vision Positioning (OPTI Mode), the Intelligent Flight Modes are not available, and the flight mode will be limited to Video Mode.
- When the GNSS signal is weak or there is no GNSS signal, you will not be able to return the drone and activate certain functions such as AI Track or AI QuickShots.
- ⊘ • Before flying, please practice and master all the drone control methods in a safe environment. For beginners, it is recommended to face the rear of the drone and keep the drone within the visual line of sight to avoid losing judgment of the drone's attitude and direction, which could lead to danger.

» 5.2 Downward Vision System

ATOM 2 is equipped with a Downward Vision System located at the bottom of the drone, consisting of a monocular camera and a TOF (Time of Flight) module. The TOF module is divided into a transmitter and a receiver, which calculates the precise altitude of the drone relative to the ground by measuring the time taken for an infrared signal to travel from the transmitter to the receiver after reflecting off the ground. Combined with the monocular camera, this allows the calculation of the drone's precise low-altitude position for high-accuracy positioning.

Observation Range

The operational height range of the Downward Vision System is 0.3 m ~ 10 m. Accurate positioning can be achieved within the range of 0.3 m ~ 5 m.

Usage Scenarios:

The vision positioning function of the Downward Vision System is suitable for environments where GNSS signals are weak or unavailable but where there is a rich surface texture and adequate ambient light, and the drone's relative altitude is between 0.3 m and 5 m. When the relative altitude exceeds 5 m, the drone will switch to Attitude Mode. Please fly with caution.

Usage Method:

The Downward Vision System automatically activates when the conditions for vision positioning are met. In Vision Positioning mode, the drone's tail indicator will flash slowly in cyan.

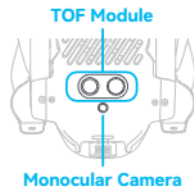

- ⚠ In OPTI Mode, the maximum flight altitude is 5 m.
- Vision positioning is only an auxiliary flight function, please always pay attention to the changes in the flight environment and positioning mode, and do not rely too much on the automatic judgment of the aircraft. Users need to control the remote controller at all times and be prepared to operate the drone manually at any time.
- The Vision System cannot work properly when flying over the following surfaces:
 1. Pure-color surface.
 2. Surface with strong reflection, such as smooth metal surface.
 3. Transparent object surface, such as water surface and glass.
 4. The moving texture, such as running pets and moving vehicles.
 5. Scenarios with drastic change of light; For example, the drone flies to outdoor space with strong light from indoor space.
 6. Places with weak or strong light.
 7. The surface with highly repetitive texture, such as floor tile with the same texture and small size, and highly consistent strip pattern.
- For the sake of safety, please check the camera and TOF transceiver tube before the flight, and clean it with a soft cloth if there is any dirt, dust, or water on it. Contact customer support if there is any damage to the Vision System.

» 5.3 Drone Tail Indicator

Startup/ Shutdown	Startup/Shutdown in progress: Green indicator is solid on			
Flight status	GNSS positioning	Vision positioning	Attitude mode	Return
	Indicator flashes slowly in green	Indicator flashes slowly in cyan	Indicator flashes slowly in blue	Indicator flashes slowly in red
Warning & error	Remote controller has no connection with the drone (disconnected)	Low battery	Sensor error	Emergency propeller stop
	Indicator is in solid blue	Indicator flashes quickly in red	Indicator is in solid red	Indicator repeatedly briefly lights up in red and then remains off for an extended period.
Upgrade & calibration	Compass calibration (horizontal)	Compass calibration (vertical)	Pairing mode	Upgrade mode
	Indicator alternately flashes between red and green	Indicator alternately flashes between blue and green	Indicator flashes quickly in green	Indicator flashes quickly in blue

» 5.4 Smart Battery

5.4.1 Function

ATOM 2's smart battery is equipped with high-energy cells and utilizes an advanced battery management system. Detailed information is as follows:

Basic Parameters			
Model: DSBT02B			
Cell Qty.	2 series	Battery Capacity	2230 mAh
Rated Voltage	7.7 V	Charge Completion Voltage	8.8 V
Charging Mode	USB-C/ Parallel Charging Hub	Max. Charge Current	USB-C: 5 V/3 A Parallel Charging Hub: 8 V/2.0 A x 3

Function	Description
Balance protection	During charging, the voltages of the battery cells are automatically balanced.
Auto-discharging protection	After being fully charged, the battery will start to auto-discharge to 50% ~ 70% of the battery level when it's left idle for 5 days to protect the cells.
Overcharge protection	The battery stops charging automatically once fully charged.
Temperature protection	Charging will stop automatically if the temperature of the battery is below 0°C or above 45°C to prevent damage.
Auto-limit of charging current	The battery will restrict the charging current automatically if an excess current is detected to protect the cells.
Overdischarge protection	Discharging stops automatically to prevent excess discharge when the battery is not in flight use. The battery will enter Hibernation mode and it's recommended to charge the battery.
Short-circuit protection	The power supply will be automatically cut if a short-circuit is detected to protect the drone and the battery.
Battery health monitoring	The BMS will monitor the battery health, and prompt warnings if a damaged battery cell is detected so you can replace the battery in time.
Communication function	Information about charge cycles and remaining battery level is transmitted to the drone and you can view it in the App.

-
- ⚠ Prolonged inactivity can negatively impact battery performance and may even cause permanent damage. To maintain battery health, recharge it approximately every three months to ensure its activity.
 - Please store the battery in a cool and dry place where children cannot reach.
 - Precautions for low-temperature environments:
 1. Batteries cannot be used for flight when the ambient temperature is below 0°C.
 2. In low temperatures, hover the drone to preheat the battery before flying.
 3. Battery output power is limited in cold environments, reducing wind resistance; fly with caution.
 4. Performance is diminished in cold, high-altitude environments; fly with caution.
 - Post-flight battery care: After flight, allow the battery to cool to the charging temperature range (0 ~ 40°C) before charging.
 - Battery safety during transport: To ensure safe transportation, keep the battery at a low charge level. Discharge the battery to below 30% before transport.
-

5.4.2 Battery Installation & Removal

Installation:

Insert the battery in the battery compartment and secure the buckle. You will hear a clicking sound when the battery is fully engaged.

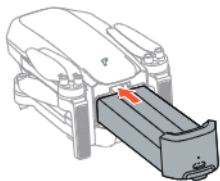

Removal:

Press the battery buckle and detach the battery from the battery compartment to remove it.

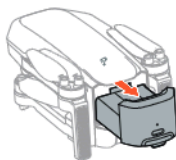

-
- ⚠ After inserting the battery, please ensure that the battery buckle snaps back into place. This is crucial for flight safety.

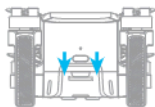

Make sure to power off the product before removing the battery.



Buckle is in position, safe



Buckle is not in position, which may result in the battery falling during flight.

5.4.3 Charging

See 3.6 for charging method

5.4.4 View Power Level

Once the battery is inserted in the drone, short press the power button to view the power level of smart battery, as shown in the picture below:

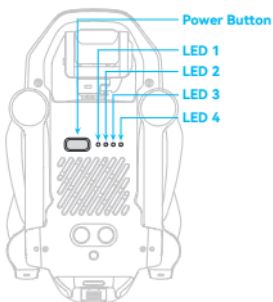

LED 1	LED 2	LED 3	LED 4	Current power level
☀	●	●	●	0% ~ 25%
☀	●	●	●	25% ~ 30%
☀	☀	●	●	30% ~ 50%
☀	☀	●	●	50% ~ 55%
☀	☀	☀	●	55% ~ 75%
☀	☀	☀	●	75% ~ 80%
☀	☀	☀	☀	80% ~ 97%
☀	☀	☀	☀	97% ~ 100%
☀ Indicator is on	☀ Indicator is flashing	● Indicator is off		

5.4.5 Operation Instructions of Smart Battery at High/Low Temperature





When the battery temperature is $< 5^{\circ}\text{C}$, the App will prompt a low temperature warning of the battery, and the battery needs to be preheated before flying.

When the battery temperature is $> 70^{\circ}\text{C}$, the App will prompt a high temperature warning of the battery, and the drone will not be able to fly.

- ⚠ • The discharge capacity will be weakened greatly and flight duration will reduce at a low temperature, which is normal.
- Avoid long-term running at a low temperature, otherwise, the battery life can be shortened.

» 5.5 Propellers

ATOM 2 uses a newly designed second-generation silent propeller, which enhances power performance while effectively reducing noise during blade rotation. The propellers are divided into clockwise and counterclockwise types. Attach the marked propellers to the motors of the marked arm, and the unmarked propellers to the motors of the unmarked arm. The two propellers attached on the same motor should be identical.

	Propeller	Installation Instructions	Schematic Diagram of Installation
Marked propeller		Attach the marked propeller blades on marked arm	
Unmarked propeller		Attach the unmarked propeller blades on unmarked arm	

- Use the the screwdriver from the package to mount the propellers.
- When replacing the propeller blades, it is easier to handle by gripping the motor with your hand.

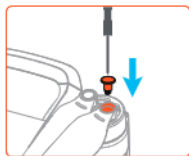

- ⚠ • The ATOM 2 propellers are not compatible with ATOM/ATOM SE/ATOM LT propellers and are currently only supported for the ATOM 2 model. Please be sure to take note when replacing the propellers.
- Make sure you attach the marked propellers to the motors of the arm with marks and the unmarked propellers to the motors of the arm without marks. Otherwise the drone will be unable to fly.
- If a propeller is damaged, remove the two propellers and screws on the corresponding motor and discard them. Use two propellers from the same package. DO NOT mix with propellers in other packages.
- Propeller blades are sharp. Handle with care. DO NOT squeeze or bend the propellers during transportation or storage.
- Purchase the propellers separately if necessary.
- Stay away from the rotating propellers and motors to avoid injuries.
- Please check the propeller blades immediately if there are any jitters or speed loss in flight, and timely replace the propellers if it's damaged or deformed.
- Make sure the motors are mounted securely and rotating smoothly. Land the drone immediately if a motor is stuck and unable to rotate freely. Stop flying the drone and contact support if there is any abnormal sound with the motor.
- Make sure that the propellers are installed securely before each flight. Check to make sure the screws on the propellers are tightened.
- ⊘ • When mount or remove the propellers, do not put the screwdriver or other foreign materials inside the motors, otherwise the motor may be damaged.



» 5.6 Gimbal and Camera

5.6.1 Three-Axis Gimbal

The ATOM 2 camera is equipped on a three-axis gimbal. The gimbal allows for tilt adjustment from +20° to -90° and yaw and roll offset adjustments from +10° to -10°. The gimbal tilt angle can be adjusted by moving the gimbal dial on the remote controller. When the flight mode is set to Video Mode, the gimbal's tilt adjustment range is from +20° to -90°; when the flight mode is not set to Video Mode, the gimbal's tilt adjustment range is from 0° to -90°.

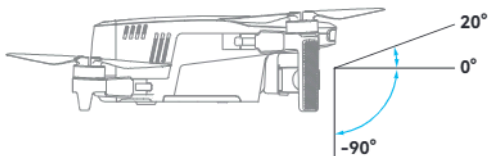

- Before powering on the drone, remove the gimbal protector. When storing or transporting, attach the gimbal protector.
 - Each time the drone is powered on, the gimbal tilt angle defaults to 0° (horizontal view). If the gimbal rotates, switch the gimbal tilt angle using Potensic Eve App or the remote controller as follows:
 1. In the Potensic Eve App, go to Settings > Control > Gimbal Settings, and select the current tilt angle (0°/-90°).
 2. Press once the C1 button on the remote controller. The default function of the C1 button is switching the gimbal tilt angle (0°/-90°), which can be customized.
 - Before takeoff, ensure there are no foreign objects around the gimbal and that the lens is clean.
-
- ⚠ The gimbal is composed of precision parts. When the drone is powered on, avoid applying excessive force to the gimbal (such as strong impacts or forcibly twisting the gimbal). If the gimbal is subjected to a collision or damage, its performance may degrade.
 - Keep the gimbal clean and avoid the intrusion of sand or other foreign objects, which may reduce the gimbal's accuracy or cause damage.
 - To ensure stable footage, the gimbal may automatically adjust its pitch angle around -90° or 0° during strong winds or sharp maneuvers to avoid limits that cause jitter.
-
- ⊘ The gimbal is connected to the drone via an elastic shock-absorbing mount, which helps eliminate camera vibration. Do not pull the gimbal forcefully. If you notice any damage to the shock-absorbing mount, please contact customer support promptly.
 - Do not modify the gimbal or attach other objects to it, as this may cause the gimbal to shake or lead to motor damage.
-

Gimbal Modes

The gimbal can operate in Stable Mode and FPV Mode to meet different recording needs. You can select the gimbal mode in the Potensic Eve App under Settings > Control > Gimbal Settings.

- **Stable Mode:** The gimbal's roll direction remains level at all times. The gimbal tilt angle can be adjusted using the gimbal dial on the remote controller. This mode is suitable for capturing stable footage.
- **FPV Mode:** The gimbal's roll direction follows the drone's roll attitude changes. The smoothness of the roll can be adjusted in the Potensic Eve App under Settings > Control > Gimbal Settings > Gimbal Mode. The gimbal tilt angle can be adjusted using the left dial on the remote controller. This mode is ideal for experiencing first-person view (FPV) flight and capturing dynamic footage.

Gimbal Fine-Tuning

When the drone is placed on a level surface and the gimbal is slightly tilted, you can use gimbal fine-tuning to correct it.

• How to Perform Gimbal Fine-Tuning

1. In the Potensic Eve App, go to Settings > Calibration > Gimbal Fine-Tuning to adjust the gimbal's horizontal and yaw angles. The adjustment range is $\pm 10^\circ$. Each tap on the "+" or "-" button adjusts the gimbal angle by $+0.1^\circ$ or -0.1° . You can also directly enter the angle value using the keyboard for adjustments.
2. Horizontal Adjustment: Tap "+" to roll to the right, and tap "-" to roll to the left.
Yaw Adjustment: Tap "+" to yaw to the right, and tap "-" to yaw to the left.
3. Tap "Default" to reset the gimbal to the default angle (both set to 0°).

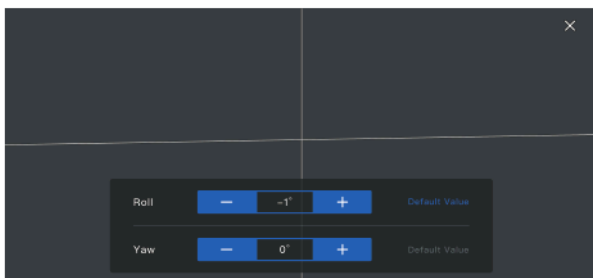

Gimbal Calibration

If the gimbal experiences startup issues, try restoring it through gimbal calibration.

• Calibration Procedure



1. Go to the Potensic Eve App > Settings > Calibration > Gimbal Calibration to begin the calibration process. Flip the drone upside down with its bottom facing up, and place it on a level surface.
2. After tapping "Start Calibration", the gimbal will begin to calibrate automatically. During this process, the calibration interface will display the drone's live video feed.
3. Wait for the progress bar to complete. When the on-screen prompt shows "Calibration Succeeded", the gimbal calibration is complete.



 • During the calibration process, do not move the drone significantly, otherwise the calibration will fail.

5.6.2 Camera

Basic Parameters	
Sensor brand	SONY
Sensor size	1/2" CMOS
Effective pixel	48MP
Aperture	F1.8
FOV	79.4°
Focus range	4 m ~ ∞
ISO range	100 ~ 6400 (Normal shooting modes) 100 ~ 25600 (AI Night)
Shutter range	1/6400 ~ 8s
Memory	microSD card (U3 or V30 and above)
Picture format	JPG/JPG+RAW (DNG)
Picture size	48MP (8000*6000)
Codec	H.264/H.265
Video format	MP4
Video Resolution	4K: 3840×2160 (16:9) @24/25/30 fps 2.7K: 2704×2028 (4:3)/2704×1520 (16:9)/1696×3000 (9:16) @24/25/30 fps FHD: 1920×1440 (4:3)/1920×1080 (16:9)/1080×1920 (9:16) @24/25/30/50/60 fps Slow Motion: 1920×1080 (16:9) @2/3/4/5 x

-  The gimbal may shake when flying in Sport Mode or strong wind. It is recommended to fly the drone in Video Mode to acquire optimal gimbal stabilization.
 - Do not touch the lens after recording for a long period of time to avoid scald.
 - Do not record video when the drone is not flying; otherwise the drone will trigger overheat protection.
-  Do not point the camera at laser beams, such as laser shows or LiDAR module of smart cars, to avoid damaging the camera sensor.
 - Use the drone within the specified ambient temperature range (0°C to 40°C) to ensure stable camera operation.
 - If the lens is dirty, use professional lens cleaning tools to clean it to avoid damaging the lens and affecting image quality.

5.6.3 Storing Photos and Videos

Videos and photos recorded by ATOM 2 will be stored on the microSD card instead of the Potensic Eve App or your phone gallery. Make sure to insert a microSD card prior to flight. Otherwise, it's unable for ATOM 2 to record videos or capture photos. Users can preview and download videos and photos from the microSD card in the Potensic Eve App. For downloading high-definition content from the microSD card, it is recommended to use the SmartTransfer feature, which offers a download speed of up to 25 MB/s.

SD Card Requirements

File format: FAT32, exFAT

Capacity: 4G ~ 512G

It is recommended to use a microSD card with U3/V30 or higher specifications. Using a microSD card with specifications lower than the recommended ones may result in certain recording settings being unavailable or pose a risk of video recording interruptions.

-
- ⚠️ • DO NOT remove or insert the microSD card from the drone when powered on. Removing or inserting the microSD card when taking photos or videos may lead to data corruption or loss, and could even damage the microSD card.
 - Potensic does not bear any responsibility for losses caused by improper handling of the microSD card by the user.
 - During the download of videos, photos, or other media, interruptions such as network disconnection or device malfunction may result in data corruption or loss. It is recommended to use a stable network connection and the officially recommended data transfer methods (RC download, SmartTransfer, or memory card copying) to minimize the risk.
-

» 5.7 Flight Record Playback



ATOM 2 supports flight record playback. Users can access flight record playback in the Potensic Eve App under Home > Me > Flight Logs. Each flight generates a set of flight data that records the duration, distance, control stick changes, and flight trajectory. Users can tap on the corresponding flight data in the Potensic Eve App to replay the flight, which helps review and analyze the operations.

If users encounter any abnormal situations during flight, they can contact customer support through the Potensic Eve App under Home > Me > Online Customer Service. If further analysis is required, users can upload the relevant flight data to help Potensic provide assistance and support more efficiently.

-
- ⚠️ • All flight data will be stored on the user's mobile device. Except when users actively upload it to the cloud, Potensic will not access any of your flight data.
-

» 5.8 SmartTransfer

SmartTransfer allows wireless connection from the drone to a mobile device via Wi-Fi (without connecting the remote controller). Users can simply use the Potensic Eve App to download photos and videos from the drone at a transfer speed of up to 25 MB/s, making content download faster and more convenient.

In the Potensic Eve App, users can access SmartTransfer by tapping  in the top left corner of the home screen or by tapping  in the top right corner of the Album.

How to Use:

1. Power on the drone, ensuring the motors are not spinning.
2. Enable Bluetooth and Wi-Fi on your mobile device, then open the Potensic Eve App.
3. On the home screen, tap Connect for SmartTransfer in the top left corner. A pop-up window will appear, showing a list of available drone models.
4. Tap Connect. Once connected, you will automatically enter the Album, where you can select files for high-speed download.

-
- 💡 • When connecting your mobile device to the drone for the first time, press the drone's power button to confirm the connection with this device.
 - To optimize the transfer speed, it is recommended to extend the drone's arms during use and ensure there are no obstacles between the mobile device and the drone, with a distance of less than 1 m.
-



- SmartTransfer is unavailable mid-flight.
- If SmartTransfer fails to connect, try the following steps:
 1. Ensure that your mobile device's Wi-Fi and Bluetooth are enabled.
 2. Keep your mobile device within 1 m of the drone, with no obstacles in between to maintain a strong Wi-Fi connection.
 3. Check if data acceleration or network assistant settings are enabled on your mobile device. These features may adjust network connections automatically, potentially affecting direct Wi-Fi transmission between the drone and your device.
 - For Android devices: Go to "Settings" and search for keywords like "Data Acceleration", "Mobile Data Boost", "Smart Network Switching", or "Network Acceleration Engine". The exact names may vary by brand. Locate and disable these features.
 - For iOS devices: Go to "Settings" > "Cellular" and scroll down to disable "Wi-Fi Assist".
 4. If the current environment has strong Wi-Fi interference, try moving to a location with less interference.

After completing these steps, restart the app and the drone, then attempt to reconnect. If the issue persists, please contact online customer support.

» 5.9 Compass Calibration

5.9.1 When to Perform Compass Calibration

1. Compass calibration is required for first-time use.
2. Flying the drone more than 500 km (310 miles) away from its last calibration location.



- Do not calibrate the compass in locations where magnetic interference may occur, such as close to magnetic deposits or large metallic structures such as parking structures, steel reinforced basements, bridges, cars, or scaffolding.
- Do not carry objects that contain ferromagnetic materials such as mobile phones near the aircraft during calibration
- Make sure the drone is at least 1.5 m (4.92 ft) above the ground when calibrating.
- It's not necessary to calibrate the compass when flying indoors.

5.9.2 Calibration Procedure

1. When calibration is required, the Potensic Eve App will pop up the calibration interface automatically, tap "Start Calibration", and the drone status indicator will alternatively flash red and green.
2. Hold the drone horizontally and rotate it 360° till the Potensic Eve App shows vertical calibration, and the drone status indicator will alternatively flash blue and green.
3. Hold the drone vertically and rotate it 360° around a vertical axis till the Potensic Eve App prompts the calibration completed.

You can also trigger compass calibration manually in the Potensic Eve App under Settings > Calibration > Compass Calibration.

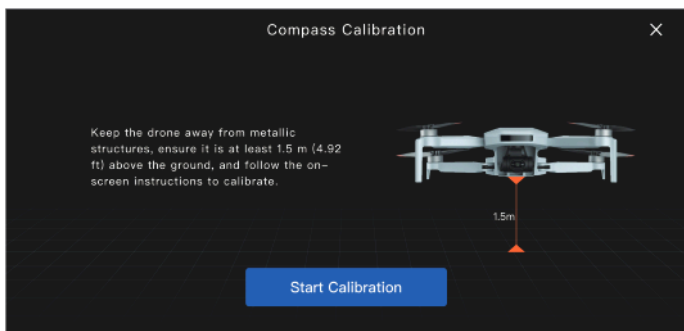

⚠ • When you get the prompt "Calibration failed" in the Potensic Eve App repeatedly, change the location and try the calibration procedure again.

🚫 • Do not calibrate compass while arms are folded.

6. Remote Controller

» 6.1 Overview

Potensic PT 1 remote controller is specifically designed by Potensic for ATOM 2. It utilizes PixSync 4.0 video transmission technology, allowing full control and configuration of the drone up to a maximum distance of 10 km in a straight line in an unobstructed, interference-free environment at a flight altitude of 120 m.

Through the App, users can view real-time HD footage captured by the drone's camera on their mobile devices. PixSync 4.0 uses a 2.4G frequency band with dual high-gain directional antennas, delivering video transmission quality of up to 1080p@30 fps. It also supports seamless switching between up to 8 adaptive channels to ensure smooth and uninterrupted HD video transmission.

The remote controller has a built-in 5200mAh battery and comes with a dedicated USB-C charging port that supports 18W fast charging. When charging a mobile device, the maximum battery life of the remote controller can reach up to 4 hours.

» 6.2 Control Stick Mode

In the Potensic Eve App, go to Settings > Control > Remote Controller Settings > Control Stick Mode to set the control stick mode. The options include Mode 1 (Right Hand Throttle), Mode 2 (Left Hand Throttle), and Custom, as shown below.

Mode 1 (Right Hand Throttle)

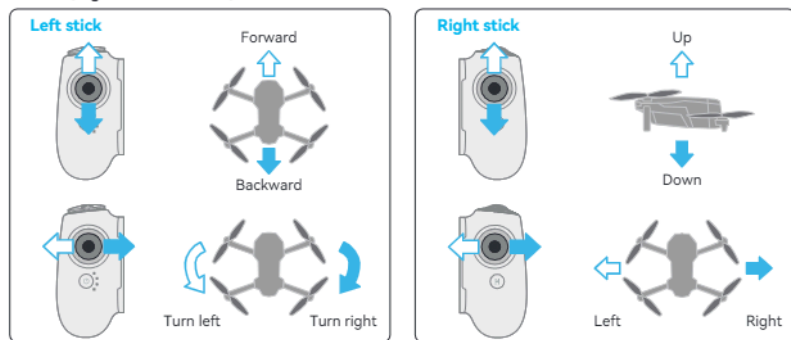

Mode 2 (Left Hand Throttle)

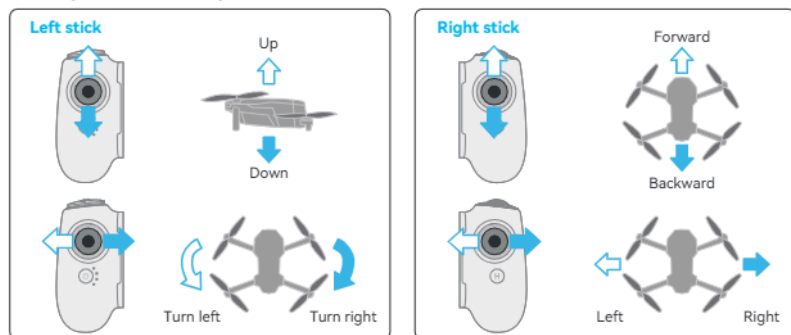

Custom

Users can customize the control stick mode according to their needs, including reversing the stick directions.

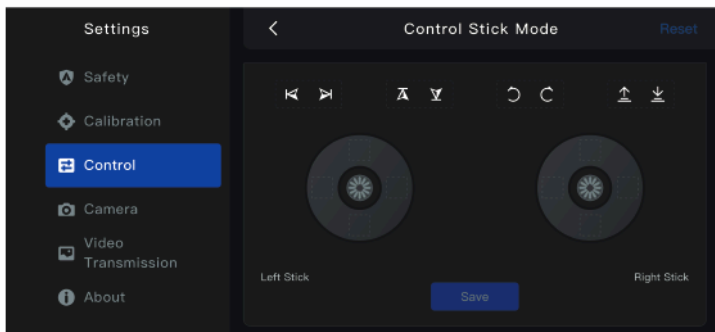

☀️ • The default control mode of the remote controller is Mode 2 (Left Hand Throttle).

» 6.3 Function

6.3.1 Indicator

As shown below, the remote controller is equipped with four white LED indicators that indicate battery level and other statuses.

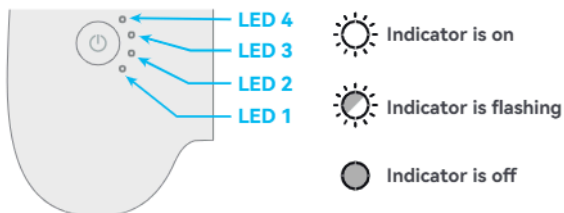

Charging Indication

LED 1	LED 2	LED 3	LED 4	Current power level of battery
☀️	●	●	●	0% ~ 25%
☀️	☀️	●	●	25% ~ 50%
☀️	☀️	☀️	●	50% ~ 75%
☀️	☀️	☀️	☀️	75% ~ 99%
☀️	☀️	☀️	☀️	99% ~ 100%

Power Indication (in use)

LED 1	LED 2	LED 3	LED 4	Current power level of battery
				0% ~ 10%
				10% ~ 25%
				25% ~ 50%
				50% ~ 75%
				75% ~ 100%

Status Indication (via LED 1)

Status	LED 1
Connected	Solid green
Not connected	Solid blue
Pairing	Fast flashing blue
Upgrading	Flashing yellow
Critically low battery	Solid red
Remote controller calibration	Solid white

6.3.2 Remote Controller Alert

The remote controller emits different alert beeps depending on its status or mode. The common alert beeps are listed in the table below:

Status	Beep
Power on/off	2 beeps
ATTI mode	4 beeps
The remote controller triggers a function, such as RTH	2 beeps
The remote controller ends a function, such as RTH	1 beep
RTH in progress	2 beeps (repeated)
Landing	1 beep (repeated)
Connected to a mobile device	1 beep
Low battery level	3 slower beeps (repeated)

- If you want to stop the continuous beeping of the remote controller during the RTH process, you can cancel the beeping by pressing once the power button.
- In the Potensic Eve App, go to Settings > Safety > Return (RTH) > Silent Return. When this option is enabled, the remote controller will beep twice only once when RTH is triggered, and will not continue to beep.
- When the remote controller's battery is low and the drone has not landed, the remote controller will emit a slow, continuous beeping sound. You can also cancel the current beeping by pressing once the power button.

6.3.3 Pairing

ATOM 2 and its remote controller are pre-paired at the factory and ready for use immediately after powering on. If you replace the remote controller or drone for any reason, you will need to re-pair them before use.

Pairing Steps:

1. Power on the remote controller and connect it to your mobile device. Go to Potensic Eve App > Settings > Calibration > Re-pair the drone to access the pairing interface.
2. Power on the drone by pressing and holding the power button. Then quickly double-press the drone's power button. The drone's tail indicator will flash rapidly, indicating that it is in pairing mode.
3. During the pairing process, the LED 1 of the remote controller will flash blue. When you hear a beep from the remote controller, it means the pairing is successful. The LED 1 of the remote controller will change from flashing blue to solid green, and the Potensic Eve App will prompt "Pairing Successful!".

-
- ⚠️ • During pairing, keep the remote controller and drone within 1 m of each other and ensure there is no 2.4G interference nearby.
 - If pairing fails, check for interference, ensure no other drones are in pairing mode, and verify that the remote controller is not too far from the drone or obstructed. Address these issues and try again.
 - Do not move or operate the remote controller or drone during the pairing process.
-





6.3.4 Emergency Propeller Stop Mid-Flight

In case of an emergency during flight where the drone needs to be stopped immediately, you can use the Emergency Propeller Stop Mid-Flight feature. Stopping the motors mid-flight will cause the drone to crash. Use this function with caution.

How to enable:

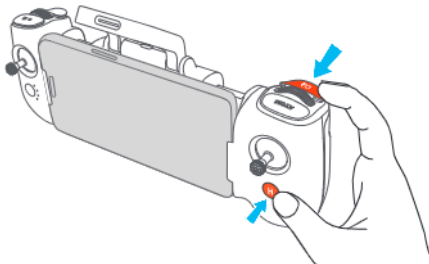
The Emergency Propeller Stop feature is disabled by default. To enable it, go to Potensic Eve App > Settings > Safety > Advanced Safety Settings > Emergency Propeller Stop Mid-Flight. After enabling, in an emergency, press and hold the C2 button and the RTH button simultaneously for 2 seconds. The motors will be stopped immediately. When using this feature, ensure the area below the drone is clear.





-
-  • The Emergency Propeller Stop Mid-Flight feature is designed for situations where the drone is out of control or in other emergencies. By immediately stopping the motors, this feature reduces the risk of the propellers causing injury to people or damage to valuable objects. The drone may be damaged upon crashing, please use this feature with caution.
-

» 6.4 Optimal Transmission Zone

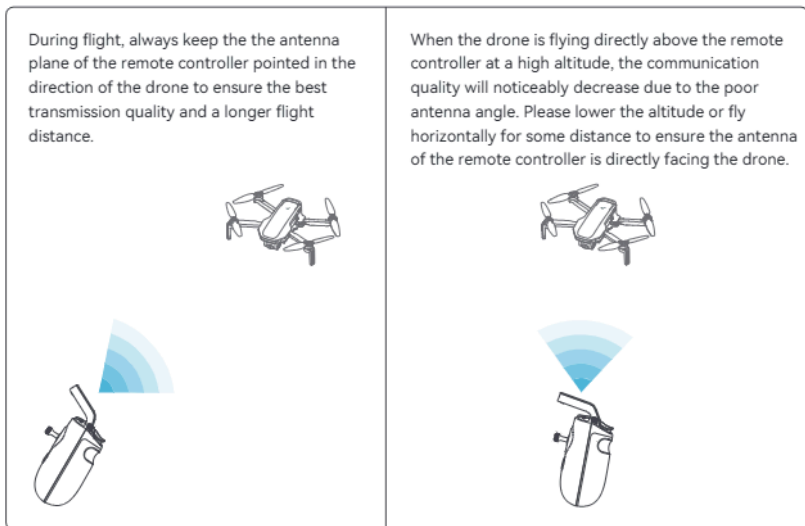
The angle of the remote controller's antenna should be adjusted promptly according to the drone's altitude and distance to ensure optimal transmission range.



-
-  • During flight, do not use other 2.4G devices simultaneously to avoid interference with the remote controller's communication.
- In actual flight, you can use the map/attitude indicator in the lower-left corner of the flight interface in the Potensic Eve App to help determine whether the remote controller is aligned with the drone. When both the drone icon  and the remote controller icon  turn green, it indicates that the remote controller is aligned with the drone.
-

» 6.5 Remote Controller Calibration

6.5.1 When to Perform Remote Controller Calibration

1. When the drone drifts automatically in one direction without any toggling of the control sticks.
2. When the drone auto-rotating sideways continuously.
3. When the control sticks are over-sensitive or lack sensitivity.

6.5.2 Calibration Procedure

1. Power on the remote controller, and connect to your mobile device. Open Potensic Eve App and go to Settings > Calibration > Remote Controller Calibration.
2. Make sure the control sticks are in the middle position and do not operate it before tapping to start the calibration.
3. Tap "Start Calibration", then follow the on-screen instructions and toggle the sticks in all directions until the Potensic Eve App displays 100%, and rotate the dial back and forth to its maximum extent.
4. When Potensic Eve App prompts "Calibration Succeeded", the remote controller calibration is completed.

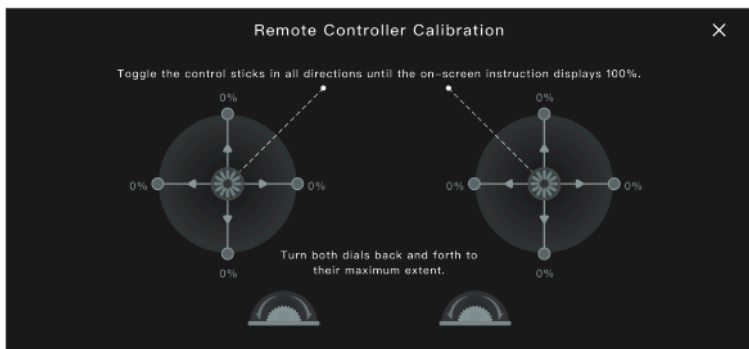

7. Potensic Eve App

» 7.1 Home Screen

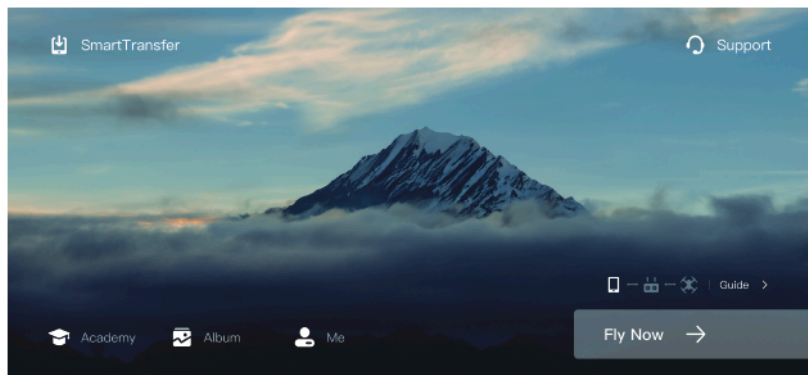

SmartTransfer

Download photos and videos from the drone to your mobile device fastly and conveniently.

Academy

Access user manuals, tutorial videos, and FAQs.

Album

View both the drone's gallery and local gallery.

Me

View account information and flight data; access the Find My Drone feature; access the store, and community updates; adjust settings like clearing cache, logging out, and deleting the account.

Fly Now

Tap to enter the flight interface.

Guide

Displays the current connection status and shows how to connect the mobile device, remote controller, and drone.

Support

Get after-sales service and support.

» 7.2 Flight Interface



1. **Back:** Tap to return to the home screen

2. **Flight Mode:** V: Video Mode N: Normal Mode S: Sport Mode

3. **System Status Bar:** Displays drone flight status.

Tap to access the Quick Settings panel, where you can view helpful tips, set flight modes, RTH altitude, virtual fence, and change HOME point.

4. **Gimbal Angle:** Displays current gimbal tilt angle. Tap to view more information.

5. **GNSS Status:** Displays the current GNSS signal strength and connected satellites. Tap to view more information (Connected satellite quantities and positioning accuracy).

6. **Video Transmission Signal Strength:** Displays the video transmission signal strength between the drone and the remote controller. Tap to view the RC channel diagram.

7. **Smart Battery Information:** Displays the current battery level and remaining flight time. Tap to view more information (time left before low battery return or forced landing; power consumption rate).

8. **Settings:** Tap to view or set parameters for safety, control, camera, video transmission and About. Refer to 7.3 Settings section for more information.

9. Flight Telemetry:



D: horizontal distance between the HOME point and the drone

H: relative altitude between the HOME point and the drone

V_D : drone horizontal speed

V_H : drone vertical speed

10. Shooting Modes:



Photo: Single, Burst, Interval Timer, BRK and 8K.



Video: Normal, AI Night, Slow Motion and CineRoll.



Panorama: 180°, Vertical, Wide Angle and Sphere.



• During video recording, tap  to capture photos simultaneously (only supported in Normal, AI Night, and Slow Motion).



11. Digital Zoom:

Displays the zoom ratio. Tap to adjust the zoom ratio. Tap and hold the icon to expand the zoom dial and drag the dial up and down to adjust the zoom ratio. Use two fingers on the screen to zoom in or out.

The camera supports 2x digital zoom in photo shot (unavailable in 8K) and up to 4x in video recording (2x in 4K, 3x in 2.7K, 4x in 1080p@24/25/30 fps but unavailable in 1080p@50/60 fps).

12. Shutter/Record Button:

Tap to take a photo or to start or stop recording a video.

13. Album:

Tap to view the captured photos and videos.

14. Camera Mode Switch:

Tap to switch between Auto  and Manual  mode. In Manual mode, you can set ISO, Shutter Speed and WB parameters by observing the EM value.

15. Shooting Parameters

Photo Auto Mode:

JPG+RAW | EV 0 | 2.3G/8G

Set photo format (JPG/JPG+RAW) and photo aspect ratio (16:9/9:16/4:3).

Adjust the EV.

Switch the display between the remaining number of photos and the available capacity of the current microSD card.

Photo Manual Mode:

ISO 3200 | SS 1/100 | WB 4900K

JPG | EM 0 | 2.3G/8G

Adjust the ISO.

Adjust the shutter speed.

Adjust the white balance.

Video Auto Mode:

1080p 30 | EV +0.3 | 00:15:28

Set the video aspect ratio/resolution/frame rate, and color mode (Standard/HDR/P-Log).

* P-Log only supports recording at resolutions of 2.7K and 4K.

- 4K: 24/25/30 fps (supports 16:9)
- 2.7K: 24/25/30 fps (supports 4:3/16:9/9:16)
- 1080p: 24/25/30/50/60 fps (supports 4:3/16:9/9:16)

Adjust the EV.

Switch the display between the remaining video recording time and the available capacity of the current microSD card.

Video Manual Mode:

ISO 3200 | SS 1/100 | WB 4900K

1080p 30 | EM +0.3 | 00:15:28

Adjust the ISO.

Adjust the shutter speed.

Adjust the white balance.

16. Flight Safety Tips

Users can enable flight safety tips in Potensic Eve App > Safety > General Settings >

Flight Safety Tips. After enabling, flight-related tips will be displayed at the bottom of the flight interface.

17. Map/Attitude Indicator

Tap the top right corner to switch to Attitude Indicator.



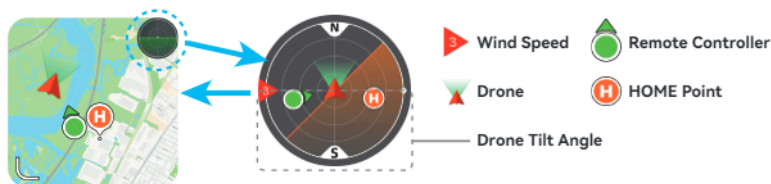

Tap the bottom left corner  or swipe down to minimize the map .

When the wind speed reaches Level 3 or above,  will be displayed.





The attitude indicator displays information of drone direction, tilt angle, remote controller direction, HOME point and more.

The attitude indicator can show the angle and direction of the drone in real time as follows:

Legend				
Tilting direction of the drone	Tilt forward: the horizon line tilts towards the upper half of the attitude indicator	Tilt backward: the horizon line tilts towards the lower half of the attitude indicator	Tilt to the right: the horizon line tilts towards the right side	Tilt to the left: the horizon line tilts towards the left side

Different Colors of the Attitude Indicator:

Legend	Description
	Green indicates that the drone is flying at a relatively small tilt angle, high precision control over the gimbal and optimal video quality can be achieved.
	Yellow indicates that the drone is flying at a relatively large tilt angle, the control precision of the gimbal may be affected, and the video quality may be reduced.
	Red indicates that the drone is flying at a very large tilt angle. If the attitude indicator frequently turns red during flight, the drone may be encountering strong winds and the video quality can be compromised. Please fly the drone back and land it as soon as possible.



- When the icons of the drone and the remote controller both turn green, it indicates that the remote controller is facing the drone which guarantees the optimal communication signal.
- After the drone is powered on and enters GNSS mode, the current GNSS coordinates will be updated as the HOME point. Pay attention to the update prompt of the HOME point.



- When the drone takes off in OPTI mode and then enters GNSS mode, the HOME point might not be the takeoff point. Pay attention to the return safety.

18. Auto Takeoff

Press and hold any blank area on the flight interface, and a "Swipe to Take off" pop-up window will appear. After swiping , the drone will automatically take off, hovering at a height of 1.2 m.

19. **Auto Landing/RTH:** Tap  then swipe to initiate either auto landing or RTH.

20. Spot Metering

Tap the flight interface in Camera Auto Mode to activate Spot Metering. Once Spot Metering is activated:

- Drag the  icon adjacent to the metering frame up or down to quickly adjust the exposure value based on the current spot metering point.
- Tap the metering frame to lock the current exposure. The exposure parameters will then become fixed values and will not adjust automatically with scene changes. Tap the metering frame again or any other area on the screen to unlock exposure.

21. **Waypoint:** Refer to Section 8.9.5 Waypoint for details.

22. Warning Prompt Bar

Displays abnormal status and warning prompts for the drone. Tap to view more information.



- Before flying, ensure your mobile device is fully charged. Even though the remote controller can recharge the mobile device, the device's battery may still drain.
- When using the Potensic Eve App, mobile cellular data is required. Please contact your wireless carrier for data charges.
- Be sure to read and understand the prompts and warning messages that pop up in the Potensic Eve App to stay aware of the drone's current status.
- If your mobile device is outdated, it may affect your user experience of the Potensic Eve App and could pose safety risks. It is recommended to replace your mobile device. Potensic is not responsible for any issues caused by outdated mobile devices.

» 7.3 Settings

Safety

Flight Settings

- Enable/disable Beginner Mode: when enabled, the drone will be restricted to flying within a cylindrical space with a radius of 30 m and a height of 30 m, and it will be limited to flying only in Video Mode. After installing the propeller guards, make sure to enable Beginner Mode.
- Flight Mode (Video/Normal/Sport)

Return to Home (RTH)

- Set drone behavior on signal lost: Return/Land/Hover.
Return: The drone will automatically ascend to the preset return altitude and then return to the HOME point when the remote controller signal is lost.
Land: The drone will automatically land in place when the remote controller signal is lost.
Hover: The drone will hover in place when the remote controller signal is lost.
- Set the return altitude.
- Enable/disable Dynamic HOME Point: after enabling, when the distance between the takeoff point and the remote controller exceeds the preset distance (and the drone is more than 100 m away from the takeoff point), you will be prompted to choose whether to set the current position of the remote controller as the new HOME point. Using a device with poor GPS accuracy may compromise the user experience. If your device's positioning accuracy is inadequate, we recommend either switching to a better mobile device or disabling this feature.
- Enable/disable Silent Return: after enabling, the remote controller will no longer beep when the drone enters RTH mode in the future. To stop the current beeping, simply press once the power button on the remote controller.

Virtual Fence

Set the maximum flight altitude and distance of the drone.

General Settings

- Set the measurement system: metric (m/km) or imperial (ft/mi). Enable/disable the flight safety tips.
- Enable/disable Takeoff with One Hand: After enabling, users can launch the drone with one hand.

Advanced Safety Settings

- Enable/disable Emergency Propeller Stop Mid-Flight: after enabling, you can press and hold the C2 and RTH buttons for 2s simultaneously to stop the motors only in an emergency situation. Note: Stopping the motors mid-flight will cause the drone to crash. Please make sure that the area below the drone is clear and open.

Remote ID: please write the relevant data required by UAS Remote ID in accordance with local laws and regulations.

Battery Information: view battery information such as temperature, current, voltage and cycle counts.

Calibration

Perform compass calibration, gimbal calibration, gimbal fine-tuning, remote controller calibration and drone re-pairing.

Control

Control Stick Settings: set the control stick mode (Mode 1/Mode 2/Custom), review the remote controller instructions, configure the customizable buttons, and adjust the sensitivity of the control sticks.

- Control Stick Mode: switch control stick modes, including Mode 1 (right hand throttle), Mode 2 (left hand throttle) and Custom.
- Review the remote controller instructions, configure the customizable buttons.
- Stick Sensitivity: allow users to adjust the control stick sensitivity for different flight modes, enabling separate adjustments for the control responsiveness during the drone's ascent/descent, rotation, and movement.

Gimbal Settings: set the gimbal maximum tilt control speed, with the gimbal tilt angle (0° - 90°), adjust the roll smoothness and set the gimbal mode (Stable/FPV Mode).

Camera

Camera Settings:

- Set WB, gridlines, color, segmental recording and coding format.
- Reset Camera Settings: tap to reset camera parameters to the default settings in Manual mode. Reset unavailable in Auto mode.

Detail Settings: Adjust Clarity and Saturation.

SD Card Settings: view microSD card storage, format microSD card and reset filename number.

Other Settings:

- Enable/disable Auto-Center Target: after enabling, the target will automatically be centered on the screen when locked onto.
- Enable/disable Defog Mode, Video Subtitles and GNSS coordinates in photo's metadata.

Video Transmission

Enable/disable Efficient Video Transmission Format: after enabling, it can enhance the video transmission quality, but some phone models may not support the display of video feed. If there is no video transmission feed after enabling, please disable this option.

View the video transmission channel map to observe the strength of environmental interference. The system will automatically select the channel with the least interference, choosing the optimal channel for the current conditions.

About

Displays information such as device model, firmware and App version.

8. Flight

This chapter introduces safe flight practices and requirements.

» 8.1 Requirements of Flight Environment

01. Do not fly in adverse weather conditions such as strong winds, rain, snow, hail, or dense fog.
02. Choose an open area free of tall buildings for your flight. Structures with significant steel reinforcement can interfere with the compass and block GNSS signals, leading to poor or failed positioning. Ensure you hear the voice prompt "HOME point updated" before continuing your flight. If flying near tall buildings, HOME point accuracy may be compromised, so closely monitor the drone's position and manually control the landing as it nears the HOME point.
03. Ensure the drone remains within visual line of sight (VLOS) during flight to avoid GNSS signal blockage by mountains or trees. For beyond-visual-line-of-sight (BVLOS) flights, ensure the drone is in good condition, you possess the necessary pilot qualifications, and the flight complies with local laws and regulations.
04. Fly away from obstacles, crowds, water surfaces, airports, highways, high-speed train stations, and urban areas unless you have obtained relevant permissions or approvals according to local laws and regulations.
05. Avoid flying near high-voltage power lines, communication base stations, or transmission towers to prevent signal interference with the remote controller.
06. Exercise caution when flying above 3000 m (9842 ft), as battery and propulsion system performance may decrease due to environmental factors. Do not exceed the specified altitude (2000 m/6562 ft when propeller guards are installed).
07. Braking distance increases with altitude. Allow sufficient braking distance for safe flight in high-altitude regions.
08. In polar regions, the drone cannot use GNSS for positioning. Please fly with caution.
09. Fly only in well-lit environments with clear surface textures and minimal glare. Daytime flights only.
10. Avoid flying near flocks of birds.
11. Exercise caution when taking off from moving surfaces (such as cars or boats). Do not take off from uniform or highly reflective surfaces (e.g., car roofs, monochrome tiles, glass).
12. Choose flat, hard surfaces for takeoff. Avoid gravel or bushy areas. Excessive vibration before unlocking the motors may prevent takeoff.
13. Be cautious when taking off from desert or sandy beach surfaces to prevent dust from entering the drone.
14. Do not use the drone in flammable or explosive environments.
15. Avoid flying in extremely cold or hot conditions to prevent hazards.
16. Use the drone, remote controller, smart battery, charging cable, and charging hub only in dry environments.
17. Do not operate the drone, remote controller, smart battery, charging cable, or charging hub in hazardous conditions such as accident sites, fires, explosions, floods, tsunamis, avalanches, landslides, earthquakes, dusty environments, or sandstorms. Avoid salt spray and mold exposure during operation.

» 8.2 Pre-Flight Checklist

Before flying, the following checks are required:

1. Ensure that the propeller strap and gimbal protector have been removed.
2. Confirm that the smart battery, remote controller, and mobile device are all sufficiently charged.
3. Ensure that the smart battery and propellers are properly installed. Check for any deformation or looseness in the propellers and screws.
4. Verify that the front and rear arms of the drone are fully extended.
5. After powering on, check that the camera and gimbal are functioning properly, and that the motors spin correctly.
6. Check whether the remote controller has the control sticks and mobile device properly installed, and ensure the remote controller antenna is correctly unfolded. Verify that all buttons are functioning normally and that Potensic Eve App is operating correctly. Additionally, check all firmware to ensure it has been updated to the latest version.
7. Ensure the microSD card is inserted and the camera lens is clean.
8. Always use original accessories. Using non-original parts may compromise the drone's safety.
9. Check the local weather to ensure it is suitable for flying. Ensure that the flying environment is open and free from interference.
10. Power on the drone on an open and flat surface. Wait for the drone to enter GNSS mode before taking off and pay attention to the HOME point location.
11. Ensure that the drone behavior on signal loss has been preset in the Potensic Eve App, and set the return altitude, maximum flight altitude, and maximum flight distance according to local laws and regulations.

» 8.3 GEO Zone

To ensure flight safety and comply with local laws and regulations, ATOM 2 will by default display GEO Zones. This feature will limit or prohibit the drone's operations in specific areas, such as Restricted Zones and Altitude Zones, ensuring that users can operate the drone safely and legally.

Before flying, please check the local GEO zone information in the Potensic Eve App by accessing the map interface.

GEO Zones are classified into two types: Restricted Zones and Altitude Zones.



Restricted Zones: In Restricted Zones, it is strictly prohibited for any drone to take off or enter the area. If the drone inadvertently enters a Restricted Zone due to extreme weather, system malfunctions, or other uncontrollable factors, the system will initiate an automatic emergency landing when it detects the drone in the Restricted Zone. This emergency landing cannot be canceled, but during the landing process, you can adjust the drone's landing position using the control sticks to ensure a safe landing.

Altitude Zones: In Altitude Zones, the drone's altitude must be strictly controlled below the specified limit for that area (with the takeoff point altitude as the zero baseline). The drone must not exceed the altitude limit when entering the altitude zone. The drone can enter the altitude zone as long as it remains below the maximum allowed altitude.

-
- Potensic will dynamically update the GEO Zone data based on local laws and regulations, as well as its own risk assessments, to help users use the drone more safely and legally.
 - Please be aware that Potensic cannot guarantee the absolute validity, completeness, or accuracy of the GEO Zone data; it is provided for reference only.
 - The GEO Zone function is automatically configured in accordance with the regulations of the user's country or region and will only be activated in countries or regions where it is legally required. In regions without mandatory requirements, this function is disabled by default. Users must learn about and strictly comply with local regulations.
-

» 8.4 Connection

Follow the steps below to connect the mobile device, remote controller and drone:

1. Follow the procedures in Chapter 4.2 and power on the remote controller.
2. Follow the procedures in Chapter 4.1 and power on the drone.
3. Launch Potensic Eve App and check the connection status. When the home screen displays  it indicates that the mobile device, remote controller and drone are successfully connected.
4. Tap  to enter the flight interface.

 • It is recommended to tap on "Guide" during the first use to view and follow the animated instructions.

» 8.5 Flight Mode

ATOM 2 supports the following flight modes, which can be switched via the Potensic Eve App.

Video Mode

Ascent speed: 2 m/s, descent speed: 2 m/s, flight speed: 6 m/s

The drone enters Beginner Mode by default when being used for the first time. The flight speed will be limited to the same as in Video Mode to allow you to familiarize yourself with the controls of the drone.

Normal Mode

Ascent speed: 4 m/s, descent speed: 3 m/s, flight speed: 10 m/s

You can exit Beginner Mode after you have mastered adequate flight skills, and the drone will switch to Normal Mode by default.

Sport Mode

Ascent speed: 5 m/s, descent speed: 4 m/s, flight speed: 16 m/s

Video Mode is recommended for aerial photography. Sport Mode is recommended if you would like to get a speedy flight experience.

Please fly with caution in Sport Mode as the responsiveness of the drone significantly increases, which means a small control stick movement on the remote controller translates into the drone moving a large distance.

-
-  • To ensure flight safety, Sport Mode is only available when the battery level is above 30%. If the battery level drops below 30% during flight in Sport Mode, the drone will automatically exit Sport Mode.
 - Be vigilant and maintain adequate maneuvering space during flight, as the responsiveness of the drone significantly increases in Sport mode.
 - The maximum speed and braking distance of the drone significantly increase in Sport Mode. A minimum braking distance of 30 m (100 ft) is required in windless conditions to ensure safety.
 - When flying in Sport Mode or strong wind, the gimbal may shake, which is normal.
 - The maximum speed may vary within a range of ± 1 m/s. Please refer to the actual experience.
-

» 8.6 Beginner Mode

When using the drone for the first time, it will default to Beginner Mode. In Beginner Mode:

1. The flight distance and altitude are limited to 0 m ~ 30 m.
2. The flight mode is restricted to Video Mode.
3. It is recommended that beginners start in Beginner Mode to learn and become familiar with the drone.

 • After exiting Beginner Mode, users can modify parameters such as RTH altitude, flight mode, flight altitude, and flight distance.

» 8.7 Takeoff/Landing/Hovering

8.7.1 Manual Takeoff/Landing

Takeoff

Step 1: Start the motors

Use a combination stick command to start the motors. Push both sticks to the bottom inner or outer corner depending on your control stick mode to start the motors. Release both sticks simultaneously once the motors are spinning.

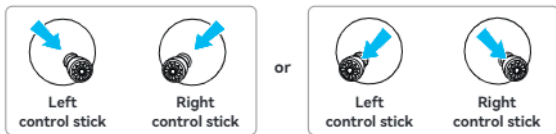

Step 2: Push throttle control stick to take off

Push the throttle control stick upwards gently as shown in the picture, release the control stick when the drone leaves ground and it will keep hovering.



Landing

Pull the throttle control stick until the drone lands on ground. Release the throttle control stick when the motors are no longer spinning.

- ⚠️ To ensure flight safety, avoid flying near airports, highways, train stations, power towers, or densely populated areas, and try to fly within visual line of sight.
- For beginners, it is recommended to always stand or walk facing the rear of the drone, which helps observe the drone's flight status and respond to emergencies, improving safety during practice.
- When taking off, always place the drone on a stable, fixed surface. Handheld or palm takeoff and landing are not supported.
- Avoid taking off with low battery level, as low-battery flights may reduce battery life. If you must force takeoff, proceed cautiously and accept any potential risks.
- When the drone is very close to the ground, airflow may prevent stable hovering. Ensure the drone's altitude exceeds 0.5 m.
- In the event of an emergency landing where the drone does not lock automatically, pull the throttle down to its limit for 3 seconds to forcibly lock the drone.

8.7.2 Auto Takeoff/Landing

Auto Takeoff

Press and hold any blank area on the flight interface of the Potensic Eve App, and a "Swipe to Take off" pop-up window will appear. After swiping , the drone will automatically take off, hovering at a height of 1.2 m.



Auto Landing

Tap  on the flight interface of the Potensic Eve App, and a "Select the landing method" pop-up window will appear. Swipe left to initiate auto landing and right to initiate RTH.

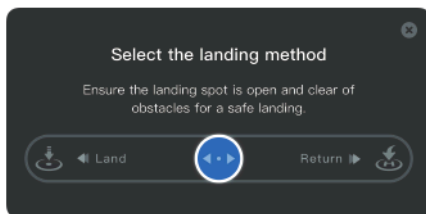

If the drone is within 20 m of the HOME point and you tap , a "Select the landing method" pop-up window will appear. If you swipe left, the drone will land immediately. If you swipe right, the drone will initiate RTH, with a minimum return altitude of 5 m. The drone will land automatically if no action is taken after a countdown of 10 seconds. Please ensure safety during this process.

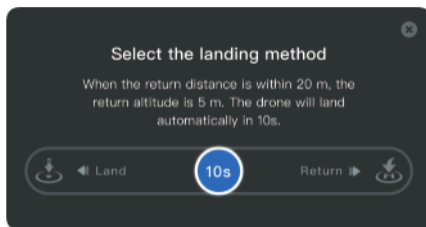

8.7.3 Takeoff with One Hand

In the Potensic Eve App, go to Settings > Safety > General Settings to enable/disable the Takeoff with One Hand feature. After enabling, users can unlock the motors and take off the drone with one hand.

1. When the control stick mode is Mode 1 (right hand throttle), press the C2 button and simultaneously pull down the right control stick for 2s to unlock the motors. Release the control stick first to take off; otherwise, release the C2 button first to stop the propellers from spinning.
2. When the control stick mode is Mode 2 (left hand throttle), press the C1 button and simultaneously pull down the left control stick for 2s to unlock the motors. Release the control stick first to take off; otherwise, release the C1 button first to stop the propellers from spinning.



3. When the remote controller's Control Stick Mode is set to Custom:

If "C1 + Left Stick" is selected: press the C1 button and simultaneously pull down the left control stick for 2s to unlock the motors. Release the control stick first to take off. Otherwise, release the C1 button first to stop the propellers from spinning.

If "C2 + Right Stick" is selected, press the C2 button and simultaneously pull down the right control stick for 2s to unlock the motors. Release the control stick first to take off. Otherwise, release the C2 button first to stop the propellers from spinning.

» 8.8 Return to Home (RTH)

8.8.1 Regular Return

The regular return consists of three steps, as follows:

1. **Ascent:** The drone ascends to the preset return altitude (this step is skipped if the drone's altitude is already higher than the return altitude).
2. **Level Flight:** The drone maintains a straight flight at the preset altitude towards the HOME point.
3. **Landing:** Once it reaches the HOME point, the drone will automatically land and stop its motors.

Return to Home (RTH) The drone must be in GNSS mode

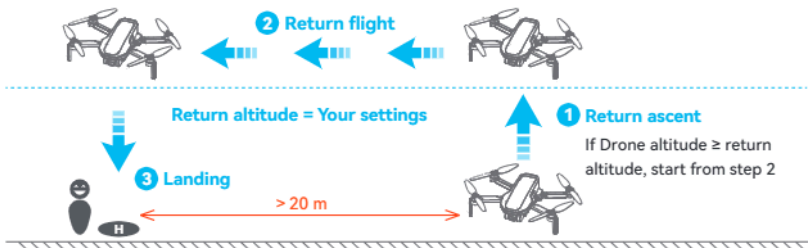

How to Start RTH

One Button RTH: Press and hold the RTH button on the remote controller for 1s or tap  in the App to pop up the menu, then swipe right to start the return.

Auto RTH: When either the drone battery level is low, the signal between the drone and the remote controller is lost or the drone is experiencing other abnormalities, Auto RTH will be triggered.

 • If there are obstacles in the surrounding environment and it's not suitable to return, it is recommended to keep the drone hovering or land the drone after losing signal in Settings to avoid colliding with the obstacles during RTH.

How to Exit RTH

Method 1: Tap  on the left of App to exit RTH.

Method 2: Press once the return button on the remote controller to exit RTH.

RTH Requirements

The drone must take off in GNSS mode and successfully record the HOME point.

If the drone takes off in OPTI mode and switches to GNSS mode mid-flight, it will not be able to return to the takeoff point.

Please pay attention to the location of the HOME point on the map and the prompts in Potensic Eve App.

-
- To ensure the safety of the return flight, please set the appropriate return altitude in the app according to the flight environment.
 - During the return course, users can still adjust the flight altitude by toggling the throttle control stick.
 - When the drone is within 20 m of the HOME point and RTH is initiated, a pop-up window will appear in the App for the user to select between landing and return. If return is selected, the return altitude is 5 m. The drone will land automatically if no action is taken after a countdown of 10 seconds. Please pay attention to flight safety.
 - Tall buildings or obstacles can block the transmission signal and cause signal loss. Do not fly behind buildings beyond the return altitude, otherwise the drone will collide with obstacles and crash during the return. If the drone enters ATTI mode due to GNSS failure or GNSS signal interference, it will not be able to return. During the return process, strong headwinds may be encountered. Lowering the flight altitude Appropriately can help reduce power consumption. If the power is insufficient, the drone will perform a forced landing in place. Please pay attention to the prompts in Potensic Eve App. Do not initiate the return when there are obstacles overhead, such as tall trees, otherwise the drone may crash during the climb.

-
- ⚠️ • Please pay attention to return safety, because ATOM 2 does not support obstacle avoidance and may crash when colliding with obstacles during the return course.
 - If the drone loses connection during the RTH process and the GNSS signal is disrupted due to interference or other environmental factors, the drone will terminate the return task and automatically enter attitude mode (ATTI). At this point, issues such as loss of positioning or drift may occur. The flight status "ATTI" will be displayed in the top left corner of the flight interface, along with a warning prompt. Please take manual control immediately. When the video transmission signal is lost, the drone will continuously search for the remote controller and GNSS signals.
 1. Once the GNSS signal is restored, the drone will reposition and automatically return to the HOME point.
 2. If the remote controller and GNSS signals cannot be restored and the battery is too low, the drone will automatically trigger the low battery emergency landing function.
 - If the drone is set to return on signal loss, and the remote controller signal is lost during the flight, the drone will automatically enter RTH mode. When the video transmission signal is disconnected, the drone and remote controller will continuously attempt to reconnect. Once the remote controller and video transmission are restored, you can regain the control of the drone.
-



8.8.2 Descending Return

How to Activate

After 10 seconds into the RTH course, if the flight altitude is greater than 150 m and the flight distance greater than 300 m, the App will prompt a message for you to confirm whether to initiate the descending return. Once confirmed, the drone will start the descending return (the drone will descend its altitude while approaching the HOME point). When its altitude descends to 120 m, the drone will switch to the regular return maintaining its current altitude till it reaches the HOME point and lands automatically.

How to Exit





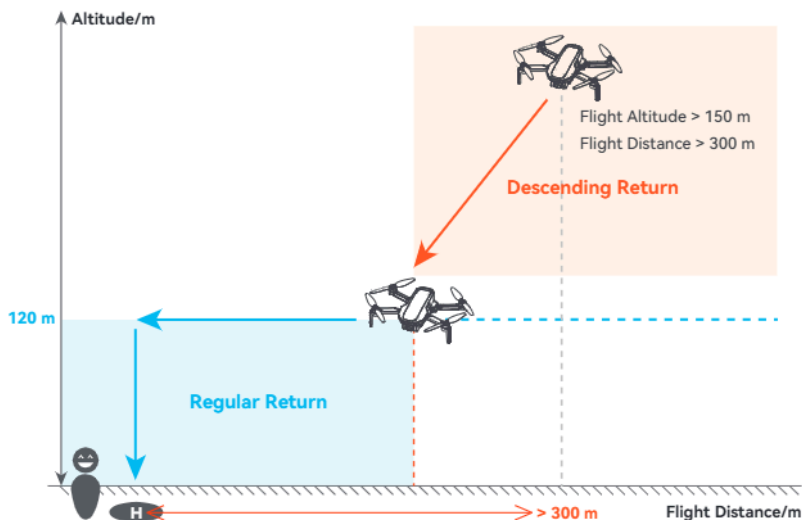



























Tap  on the left of the App interface or keep pushing the throttle control stick up for 2 seconds to exit the descending return. The drone will switch to the regular return maintaining the current altitude.

-  1. When encountering strong winds, the descending return can save power consumption and guarantee a more successful return.
 - 2. If the drone is disconnected from the remote controller during the descending return, it will switch to the regular return.
-
-  • This product does not have an obstacle avoidance function. Please pay attention to flight safety during the return process.
 - This feature is only available for countries or regions where drones are legally allowed to fly over 120 m.



» 8.9 Intelligent Flight Mode

8.9.1 AI QuickShots

<p>Introduction</p>	<p>AI QuickShots shooting modes include Pull-Away, Rocket, Circle, Spiral, Boomerang and Dolly Zoom.</p> <p>The drone records the target according to the selected shooting mode and automatically generates a short video. Users can preview the video in low resolution in Album and view the high resolution version after downloading.</p>																				
<p>How to Activate</p>	<ol style="list-style-type: none"> 1. Launch the drone and take off. 2. In video recording mode, drag-select the subject in the flight interface of the Potensic Eve App and a pop-up window will appear at the bottom, tap AI QuickShots. 3. Select a shooting mode and set the parameters. Tap  and the drone will begin recording. 																				
<p>How to Exit</p>	<ol style="list-style-type: none"> 1. Tap  on the right of the flight interface to exit AI QuickShots. 2. Toggle any control stick or press once the RTH button on the remote controller to exit AI QuickShots. 																				
<p>Explanation</p>	<table border="1"> <thead> <tr> <th>Mode</th> <th>Description</th> <th>Adjustable Parameter</th> </tr> </thead> <tbody> <tr> <td> Pull-Away</td> <td>The drone flies backward and ascends with the camera locked on the subject.</td> <td rowspan="2">Return to the starting point after finishing recording?  Yes  No</td> </tr> <tr> <td> Rocket</td> <td>The drone ascends vertically with the camera pointing downward at the subject.</td> </tr> <tr> <td> Dolly Zoom</td> <td>Drone flies backward in gimbal's view while zooming in.</td> <td rowspan="3">Flight direction (clockwise/counterclockwise)  Clockwise  Counterclockwise</td> </tr> <tr> <td> Circle</td> <td>The drone circles around the subject starting from current position.</td> </tr> <tr> <td> Spiral</td> <td>The drone ascends and spirals around the subject.</td> </tr> <tr> <td> Boomerang</td> <td>The drone flies around the subject in an oval path, ascending as it flies away from its starting point to the farthest distance and descending as it flies backward.</td> <td>Number of laps (choose from 1-3)</td> </tr> </tbody> </table>	Mode	Description	Adjustable Parameter	 Pull-Away	The drone flies backward and ascends with the camera locked on the subject.	Return to the starting point after finishing recording?  Yes  No	 Rocket	The drone ascends vertically with the camera pointing downward at the subject.	 Dolly Zoom	Drone flies backward in gimbal's view while zooming in.	Flight direction (clockwise/counterclockwise)  Clockwise  Counterclockwise	 Circle	The drone circles around the subject starting from current position.	 Spiral	The drone ascends and spirals around the subject.	 Boomerang	The drone flies around the subject in an oval path, ascending as it flies away from its starting point to the farthest distance and descending as it flies backward.	Number of laps (choose from 1-3)		
Mode	Description	Adjustable Parameter																			
 Pull-Away	The drone flies backward and ascends with the camera locked on the subject.	Return to the starting point after finishing recording?  Yes  No																			
 Rocket	The drone ascends vertically with the camera pointing downward at the subject.																				
 Dolly Zoom	Drone flies backward in gimbal's view while zooming in.	Flight direction (clockwise/counterclockwise)  Clockwise  Counterclockwise																			
 Circle	The drone circles around the subject starting from current position.																				
 Spiral	The drone ascends and spirals around the subject.																				
 Boomerang	The drone flies around the subject in an oval path, ascending as it flies away from its starting point to the farthest distance and descending as it flies backward.	Number of laps (choose from 1-3)																			



• AI QuickShots Activation Requirements:







- 1) The drone must be airborne and in GNSS mode.
- 2) A microSD card must be inserted with available storage.
- 3) The battery must be sufficiently charged.
- 4) The drone must not be in an automatic flight mode (e.g., RTH, landing, etc.).



• Use AI QuickShots in open, unobstructed areas, and always be aware of people, animals, buildings, or other obstacles in the flight path.

- If you are unfamiliar with the AI QuickShots flight path, start with shorter flight distances.
 - Be ready to toggle any control stick in an emergency to stop AI QuickShots, at which point the drone will hover in place.
 - Pay attention to objects around the drone and use manual control to avoid collisions or signal interference.
 - Avoid using AI QuickShots near buildings or in areas with GNSS signal obstructions, as this may cause the drone's flight path to become unstable.
 - Always adhere to local privacy laws and regulations when using AI QuickShots.
 - QuickShots is not available in the following situations:
 - 1) The drone is not airborne.
 - 2) GNSS signal is weak.
 - 3) No microSD card is inserted, or the microSD card is full.
 - 4) The battery level is low.
 - 5) The flight altitude is insufficient.
 - 6) The drone has reached the virtual fence.
 - DO NOT use AI QuickShots in any of the following situations where the Downward Vision System may not work properly:
 - 1) When the subject is blocked from view for extended periods or is outside the drone's line of sight.
 - 2) When the subject is more than 50 m away from the drone.
 - 3) When the subject blends in with the surrounding environment in color or pattern.
 - 4) When the subject is airborne.
 - 5) When the subject moves at high speeds.
 - 6) In extremely dark or overly bright environments.
 - AI QuickShots does not support filming in 1080p@60/50 fps format.
 - The gimbal's tilt angle cannot be adjusted while the subject is locked in AI QuickShots.
-

8.9.2 AI Tracking

<p>Introduction</p>	<p>AI Track includes Parallel, Spotlight, and Follow. The drone will fly automatically based on the track mode selected by the user and the subject. Users can choose whether to automatically start recording when activating AI Track. After enabling, a video will be automatically generated after finishing AI Track. You can preview the video in low resolution in Album and view the high resolution version after downloading.</p>			
<p>How to Activate</p>	<ol style="list-style-type: none"> 1. Launch the drone and take off. 2. In video recording mode, drag-select the subject in the flight interface of the Potensic Eve App and a pop-up window will appear at the bottom, and the default mode is AI Track-Spotlight. 3. Select a shooting mode and set the parameters. Tap  and the drone will begin tracking. 			
<p>How to Exit</p>	<ol style="list-style-type: none"> 1. Tap  on the left of the flight interface to exit AI Track. 2. Press once the RTH button on the remote controller to exit AI Track. 			
<p>Explanation</p>	<p>Mode</p>	<p>Description</p>	<p>Supported Subjects</p>	<p>Adjustable Parameter</p>
<p> Spotlight</p>	<p>The drone does not fly automatically, but the camera remains locked on the subject. Using the control sticks to manually move the drone:</p> <ul style="list-style-type: none"> · Toggle the throttle stick to adjust the altitude from the subject. · Toggle the pitch stick to adjust the distance from the subject. · Toggle the roll stick to circle the subject. · Toggle the yaw stick to adjust the frame. 	<ul style="list-style-type: none"> · Stationary subjects · Moving subjects (only vehicles, boats, and people) 	<p>Choose whether to automatically start recording when activated</p>	
<p> Parallel</p>	<p>The drone will maintain a parallel trajectory with the subject, flying alongside it.</p> 	<ul style="list-style-type: none"> · Moving subjects (only vehicles, boats, and people) 	<p><input checked="" type="checkbox"/> Enable</p> <p><input type="checkbox"/> Disable</p>	
<p> Follow</p>	<p>The drone will automatically follow behind the target.</p>			



- AI Track is unavailable when the drone is not airborne.
- During Parallel and Follow modes, the gimbal dial and camera control dial will not respond to any inputs.
- If the subject is lost, the drone will hover in place.
- If the subject approaches the drone, it will hover instead of flying backward.
- The gimbal tilt angle must be between -75° and -25° for AI Track to lock the target.
- The flight altitude for AI Track must exceed 4 m.
- The maximum supported speed for AI Track is 8 m/s.
- When using AI Track, it is recommended that the subject accelerates or decelerates gradually, with an average movement speed not exceeding 4 m/s to ensure tracking stability.



- Use AI Track in open, unobstructed environments and always watch for obstacles such as people, animals, or buildings along the flight path.
 - Do not use AI Track near buildings or in areas where GNSS signals may be blocked, as this could lead to unstable flight paths or unexpected situations.
 - In Parallel or Follow modes, any movement of the remote controller control sticks will cause the drone to exit AI Track and hover in place.
 - Always adhere to local privacy laws and regulations when using the AI Track feature.
 - Use AI Track with caution in the following scenarios:
 1. When the subject moves on non-level surfaces (e.g., slopes).
 2. When the subject undergoes significant shape changes during movement.
 3. When the subject is obstructed or out of sight for extended periods.
 4. When the subject is moving at high speeds.
 5. When the subject closely resembles the surrounding environment in color or pattern.
 6. In very dark or overly bright environments.
 - Recommended AI Track distances:
 - For a human target, the recommended horizontal distance is 5 m ~ 10 m, with an altitude of 4 m ~ 10 m.
 - For vehicles or boats, the recommended horizontal distance is 20 ~ 50 m, with an altitude of 10 m ~ 50 m.
 - Exceeding these ranges may reduce the target recognition success rate.
-



8.9.3 Cruise Control

The cruise control feature enables the drone to lock the current control stick input of the remote controller when conditions permit, and to automatically fly at the speed corresponding to the current control stick input. Without the need to continually move the control sticks, long distance flights become more effortless. The cruise control feature also supports control stick input incorporation (pitch stick and roll stick), allowing for more creative flight paths.









Using Cruise Control

Using Cruise Control	Set the Cruise Control Button: By default, press twice the C2 button on the remote controller to enable, disable, or update Cruise Control. Users can customize the cruise control button in the Potensic Eve App by going to Settings > Control > Remote Controller Settings > Button Customization.
Enter Cruise Control	During flight, by moving either the pitch or roll stick and then press twice the C2 button on the remote controller (or the custom Cruise Control button if you have reconfigured it), the drone will activate Cruise Control, flying at the current speed corresponding to the control stick input.
Update Cruise Control	During Cruise Control, if the control sticks are toggled again, the drone will incorporate the new stick input into its flight. If the custom Cruise Control button is pressed again at this time, Cruise Control will be updated, and the drone will continue flying at the new cruise speed based on the incorporated control stick inputs.
Exit Cruise Control	<ol style="list-style-type: none">1. Press the cruise control button without a control stick input;2. Press the RTH button on the remote controller;3. Tap  on the left of the flight interface. * After exiting Cruise Control, the drone will hover in place.



-  During Cruise Control, the throttle stick and yaw stick can be controlled in real-time, but throttle and yaw stick inputs cannot be incorporated to the cruise control, meaning altitude and heading are not supported for Cruise Control.
- Cruise Control can be activated while flying the drone in Normal, Video, or Sport Mode.
-  Cruise Control cannot be activated without a control stick input.
- The drone cannot enter or will exit Cruise Control in the following situations:
 1. No GNSS signal;
 2. Drone battery level is $\leq 10\%$;
 3. Low battery return is triggered;
 4. Connection between the drone and the remote controller is lost;
 5. The drone is near the virtual fence, or GEO Zone limits.

8.9.4 CineRoll

Introduction	<p>In CineRoll mode, the drone flies forward at a user-defined speed while rotating the camera in the selected direction to capture dynamic video footage. The drone automatically generates a video. Users can preview the video in low resolution in Album and view the high resolution version after downloading.</p>		
How to Activate	<ol style="list-style-type: none"> 1. Launch the drone and take off. 2. In the Potensic Eve App flight interface, select Video > CineRoll to enter CineRoll mode. 3. After setting the parameters, the interface will display the estimated forward flight distance. Tap  to start CineRoll Camera. <p>* Do not operate the control sticks before CineRoll activation; ensure the drone remains in a stable hover.</p> 		
How to Exit	<ol style="list-style-type: none"> 1. Tap  on the right side of the flight interface to stop CineRoll Camera. 2. Toggle any control stick or press once the RTH button on the remote controller to stop CineRoll Camera and hover in place. 		
Adjustable Parameter	<p>Return to the starting point after finishing recording?</p> <p> Yes</p> <p> No</p>	<p>Rotation Direction (Clockwise/Counterclockwise)</p> <p> Clockwise</p> <p> Counterclockwise</p>	<p>Flight Speed</p> <p></p> <p>(Adjust Speed 1 m/s ~ 5 m/s)</p>

-  • CineRoll Activation Requirements
 - 1) Drone must be airborne and in GNSS mode.
 - 2) Flight Altitude > 4 m.
 - 3) Battery level > 10%.
 - 4) microSD Card inserted with available space.
 - 5) Drone must not be in automated flight (e.g., Returning, Landing).

-  • Use CineRoll only in open, unobstructed areas, and always be aware of people, animals, buildings, or other obstacles in the flight path .
- Avoid using CineRoll near buildings or in areas with GNSS signal obstructions, as this may cause the drone's flight path to become unstable. .
- Be ready to toggle any control stick in an emergency to stop CineRoll, at which point the drone will hover in place.
- Pay attention to objects around the drone and use manual control to avoid collisions or signal interference.
- Always adhere to local privacy laws and regulations when using CineRoll.

8.9.5 Waypoint

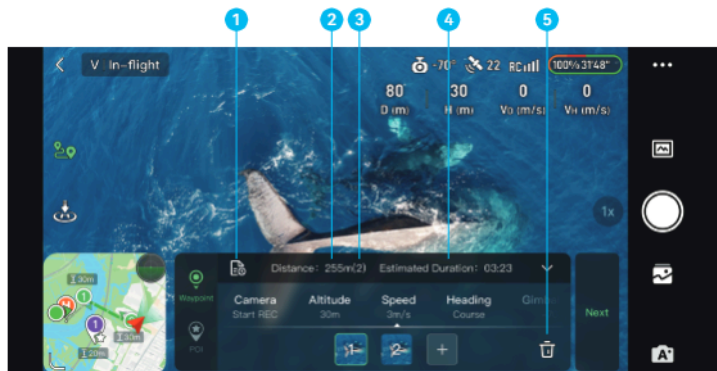

The Waypoint function allows users to pre-set waypoints on the map or in the actual scene, after which the system will automatically generate a flight path based on these waypoints. The drone can then automatically fly and shoot video along the preset trajectory according to the parameters defined by the user. Captured files can be previewed in low resolution within the Album and viewed in high resolution after downloading. Waypoint missions can be saved in the Task List, enabling one-touch repeat flights for easy repetition. By repeatedly executing the same mission at different times, users can effortlessly document temporal changes such as seasonal or daytime-to-nighttime transitions (in order to ensure proper effectiveness, the takeoff altitude for each mission should remain consistent).





1. Task List
2. Estimated Flight Distance
3. Total Number of Waypoints
4. Estimated Flight Time
5. Delete Waypoint/Point of Interest (POI)

Using Waypoint

1. Activate Waypoint	Click the Waypoint icon  on the left side of the flight interface to enter the Waypoint interface.
2. Add Waypoint/POI	Create Waypoints in the Flight Interface: In the Waypoint operation panel, tap "+" to add a waypoint/POI. Remote Controller: Press the C1 button once on the remote controller to add a waypoint, or press the C2 button once to add a POI. Add waypoints to the map: Enter map view and tap on the desired location on the map to add a waypoint/POI.
3. Set Waypoint/POI Parameters	Waypoint Parameter Settings: Camera action, altitude of drone relative to takeoff point, speed, heading, pitch angle of gimbal, zoom ratio, and hovering time. POI Parameter Settings: Altitude and link waypoints.
4. After completing the parameter settings for waypoint/POI, tap "Next" to configure the trajectory parameters.	Waypoint Sequence: Forward Flight/Reverse Flight
	Global Speed Setting: 0.5 m/s ~ 10 m/s
	Signal Lost: Return/Continue Mission
	End of Flight: Return/ Hover/Land/Back to Start
	Waypoint Altitude: Custom/Global Settings

<p>5. After completing the trajectory parameter settings, tap "Go", and the drone will initiate the Waypoint mission.</p>	
<p>6. Exit Waypoint</p>	<ol style="list-style-type: none"> 1) Tap the Waypoint icon  on the left side of the flight interface again to exit the Waypoint. The current trajectory can also be saved to the task list. 2) Tap the left side of the mission progress bar  to abort the Waypoint mission, causing the drone to hover in place. 3) Fully deflect the roll or pitch control stick in any direction to abort the Waypoint mission, causing the drone to hover in place. 4) Press the Return to Home (RTH) Button once on the remote controller to abort the Waypoint and cause the drone to hover in place.
<p>7. View Historical Waypoint Missions</p>	<p>You can view saved Waypoint missions in the task list. Click on a historical mission to display its trajectory on the map. Users can then readjust the mission settings and save this as a new version.</p>

-  • A maximum of 200 waypoints/POI can be added in a single Waypoint mission.
- On the map view, press and hold any waypoint/POI to drag and modify its position.
- Before the drone takes off, adding waypoints is only supported via map view.
- POI altitude is the height of the target faced by the drone during a Waypoint mission.
- When performing a Waypoint mission, the flight mode will automatically switch to Normal (N).
- If the camera is set to "None", the drone will only fly automatically; camera operation must be controlled manually during the mission.
- If the drone heading and gimbal pitch are set toward a POI, that POI will automatically link to the corresponding waypoint.

-  • Please use the Waypoint function in an open, obstruction-free environment, and always remain aware of potential obstacles such as people, animals, or buildings along the flight path.
- During Waypoint, continuously monitor the surrounding environment and manually exit the Waypoint if necessary to avoid accidents (e.g., collisions).
- When using the Waypoint function, users must comply with all local laws and regulations regarding privacy rights.
- When using Waypoint in the European Union, the Signal Lost cannot be set to "Continue Mission" during mission execution.

9. Appendix

» 9.1 Specification & Parameters

Drone	
Model	DSDR23A
Takeoff Weight ^[1]	245 g
Dimensions	Folded: 88×143×58 mm Unfolded (with propellers): 300×252×58 mm Unfolded (without propellers): 210×152×58 mm
Diagonal Dimension	219 mm
Max Flight Speed (Sport Mode)	Ascent: 5 m/s Descent: 4 m/s Horizontal: 16 m/s
Max Wind Speed Resistance	10.7 m/s (Level 5)
Max Flight Altitude	120 m (subject to local regulations)
Max Takeoff Altitude	4000 m
Max Hovering Time ^[2]	29 minutes
Max Flight Time ^[3]	32 minutes
Operating Temperature	0°C to 40°C
GNSS	GPS+GLONASS+Galileo+BeiDou
Hovering Accuracy Range (windless or breezy)	Vertical: ±0.1 m (with vision positioning) ±0.5 m (with GNSS positioning) Horizontal: ±0.3 m (with vision positioning) ±1.5 m (with GNSS positioning)
Payload ^[4]	Not supported

Video Transmission / Wi-Fi / Bluetooth	
Operating Frequency	2.400 ~ 2.4835 GHz
Transmitter Power (EIRP)	FCC: <24 dBm CE: <20 dBm
Live View Quality	1080p@30 fps
Latency ^[5]	120 ms
Max Transmission Bitrate ^[6]	6 Mbps
Max Transmission Distance ^[7]	10 km
Antennas	Dual antennas
Wi-Fi Protocol	802.11 a/b/g/n/ac
Wi-Fi Operating Frequency and Transmitter Power (EIRP)	2.4 GHz: <17 dBm (FCC/CE/SRRC) 5 GHz: <13 dBm (FCC/CE/SRRC)
Max Wi-Fi Download Speed	Wi-Fi 5 & 5 GHz: 25 MB/s
Bluetooth Protocol	Bluetooth 4.0/4.2
Bluetooth Operating Frequency	2.400 ~ 2.4835 GHz
Bluetooth Transmitter Power (EIRP)	<8 dBm
Wi-Fi & Bluetooth Antenna	Single antenna

Camera	
Image Sensor	1/2-inch CMOS, Effective Pixels: 48MP
Lens	FOV: 79.4° Equivalent Focal Length: ≈26 mm Aperture: f/1.8 Focus: 4 m to ~
ISO Range	Normal video mode: 100 ~ 6400 AI Night: 100 ~ 25600
Shutter Speed	1/6400 s ~ 8 s
Max Image Size	8000×6000 (4:3)
Max Vertical Image Size	1696×3000 (9:16)
Still Photography Modes	Single shot JPG: 12MP and 48MP Single shot JPG+RAW: 12MP BRK: 3/5 frames (12MP+JPG) Burst shooting: up to 7 frames (12MP+JPG) Interval timer shooting: 2/3/4/5/6/7/8/9/10/15/20/25/30 s (12MP+JPG) Panorama: 180°, Vertical, Wide Angle and Sphere.
Image Format	JPG/JPG+RAW(DNG)
Video Resolution	4K: 3840×2160 (16:9)@24/25/30 fps 2.7K: 2704×2028 (4:3)/2704×1520 (16:9)/1696×3000 (9:16)@24/25/30 fps FHD: 1920×1440 (4:3)/1920×1080 (16:9)/1080×1920 (9:16)@24/25/30/50/60 fps Slow Motion: 1920×1080 (16:9)@2/3/4/5 x
Video Format	MP4 (H.264/H.265)
Max Video Bitrate	80 Mbps
Storage	microSD card (U3 or V30 rating or above)
Supported File System	FAT32 (≤32 GB) exFAT (>32 GB)
Color Mode	HDR, P-Log
Defog Mode	Yes
Digital Zoom	4K: 1-2x, 2.7K: 1-3x, FHD: 1-4x
AI QuickShots	Pull-Away, Spiral, Rocket, Circle, Boomerang and Dolly Zoom
AI Track	Yes

Downward Vision System	
Precision Hovering Range ^[8]	0.3 m ~ 5 m
Unavailable Situations	<ol style="list-style-type: none"> 1. Monochrome surfaces, such as pure black or pure white. 2. Surfaces with strong reflections, such as smooth metal surfaces. 3. Transparent object surfaces, such as water or glass. 4. Surfaces of moving objects, such as running pets, grass blown by strong wind, or above a crowd of people. 5. Scenes with dramatic changes in lighting, such as flying suddenly from indoors to bright outdoor light. 6. Environments that are very dark or very bright. 7. Surfaces with highly repetitive textures or patterns, such as small tiles with the same design. 8. Surfaces with highly uniform stripes.

Gimbal	
Mechanical Range	Tilt: -125° to +45° Roll: ±45° Pan: ±30°
Controllable Range	Tilt: -90° to +20° Roll: +35°
Max Control Speed (tilt)	100°/s
Angular Vibration Range ^[9]	±0.01°

Remote Controller	
Model	DSRC23A
Battery Type	Lithium-ion battery pack
Battery Capacity	18.72 Wh (5200 mAh)
Charging Port	USB-C, supporting up to 18W PD fast charge
Operating Temperature	0°C to 40°C
Supported Mobile Device Port Type	Lightning, USB-C, Micro-USB * Using a mobile device with Micro-USB port requires the Standard Micro-USB connector, which is sold separately.
Max Operating Time ^[10]	4 hours
Video Transmission System	PixSync 4.0
Max Supported Mobile Device Size	L: 170 mm W: 100 mm H: 12.5 mm * For mobile devices with protruding rear cameras, the maximum supported thickness is 18 mm.
Fastest Charging Time	2 hours (using an 18W PD fast charger)

Smart Battery	
Model	DSBT02B
Capacity	2230 mAh
Energy	17.18 Wh
Weight	84 g
Nominal Voltage	7.7 V
Type	Li-Po 2S
Operating Temperature	0°C to 40°C
Charging Method	1. USB-C (max 5 V/3 A) 2. Parallel Charging Hub (supports simultaneous charging for 3 batteries at 18W each)
Charging Temperature	0°C to 40°C
Fastest Charging Time	1.3 hours (using the Parallel Charging Hub)

- [1] Standard drone weight (including the flight battery, propellers and a microSD card). The actual product weight may vary due to differences in batch materials and external factors. Registration is not required in some countries and regions. Always check and strictly abide by local laws and regulations before flying.
- [2] The maximum hovering time is measured at an ambient temperature of approximately 25°C in a laboratory environment, at a hovering height of 1.5 m, switched to 1080p/24 fps video recording mode (without video recording operation during flight), and hovering from 100% battery charge until 0%. The specific results may vary due to external environment, operating methods, and firmware version. Please refer to the actual experience for accurate results.
- [3] The maximum flight time is measured at an ambient temperature of approximately 25°C in a windless environment, flying forward at a constant speed of 5 m/s, switched to 1080p/24 fps video recording mode (without video recording operation during flight) from 100% battery charge until 0%. The specific results may vary due to external environment, operating methods, and firmware version. Please refer to the actual experience for accurate results.
- [4] Increase in drone weight can affect flight propulsion. Do not mount additional payloads or accessories from third-party sources to avoid insufficient propulsion.
- [5] This data is from laboratory measurements, and the specific results may vary depending on the actual usage scenario and the mobile device.
- [6] The average bitrate for video transmission is 5 Mbps, with peaks reaching up to 6 Mbps. The specific results may vary based on actual environmental conditions, such as interference and distance.
- [7] Measured in an unobstructed outdoor environment free of interference at an altitude of 120 m with the remote controller antenna pointing toward the drone. The above data shows the farthest communication range for one-way, non-return flights under Normal Mode. Always pay attention to RTH prompts in the Potensic Eve App during your flight.
- [8] The ideal conditions to achieve this altitude range include sufficient light, a ground surface made of diffuse reflective material with rich texture, and reflectivity greater than 20% (such as cement pavement, etc.).
- [9] Measured at the standard ambient temperature (0°C - 40°C) in a windless environment, with the drone set to Normal Mode.
- [10] Measured in an indoor environment with no obvious interference when the drone is within 10 m of the remote controller and from 100% battery charge until 0%.

-
-  • If the ATOM 2 remains idle in standby too long, its temperature may keep rising. Exceeding 55°C, the drone enters Low Power Mode, limiting it to 1080p 24 fps recording and disabling other functions. If the temperature continues to rise, it will shut down for cooling. To avoid this, launch the drone promptly to help it cool down. Once flying, it will leave Low Power Mode, allowing normal adjustment of shooting settings.
-

» 9.2 Post-Flight Checklist

- Make sure to perform a visual inspection so that the drone, remote controller, gimbal camera, batteries, and propellers are in good condition. Contact customer support if any damage is noticed.
- Make sure that the camera lens and vision system sensors are clean.
- Make sure to store the drone correctly before transporting it.

» 9.3 Maintenance Instructions

To avoid serious injury to children and animals, observe the following rule:

1. Small parts, such as cables and straps, are dangerous if swallowed. Keep all parts out of reach of children and animals.
2. Store the Smart Battery and remote controller in a cool, dry place away from direct sunlight to ensure the built-in LiPo battery does NOT overheat. Recommended storage temperature: between 22°C and 28°C (71°F and 82°F) for storage periods of more than three months. Never store in environments outside the temperature range of -10°C to 45°C (14°F to 113°F)
3. DO NOT allow the camera to come into contact with or become immersed in water or other liquids. If it gets wet, wipe dry with a soft, absorbent cloth. Turning on a drone that has fallen in water may cause permanent component damage. DO NOT use substances containing alcohol, benzene, thinners, or other flammable substances to clean or maintain the camera. DO NOT store the camera in humid or dusty areas.
4. Check every drone part after any crash or serious impact. If there are any problems or questions, contact Potensic support.
5. Regularly check the Battery Level Indicators to see the current battery level and overall battery life. The battery is rated for 250 cycles. It is not recommended to continue use afterward.
6. Make sure to transport the drone with the arms folded when powered off.
7. Make sure to transport the remote controller with antennas folded when powered off.
8. The battery will enter sleep mode after long-term storage. Charge the battery to exit from sleep mode.
9. Store the drone, remote controller, battery, and charger in a dry environment.
10. Remove the battery before servicing the drone (e.g., cleaning or attaching and detaching the propellers). Make sure that the drone and the propellers are clean by removing any dirt or dust with a soft cloth. Do not clean the drone with a wet cloth or use a cleanser that contains alcohol. Liquids can penetrate the drone housing, which can cause a short circuit and destroy the electronics.
11. Make sure to turn off the battery to replace or to check the propellers.

» 9.4 Troubleshooting

1. Why can the battery not be used before the first flight?
The battery must be activated by charging before using it for the first time.
2. No function
Check if the smart battery and the remote controller are activated by charging. If the problem persists, contact customer support.
3. Power-on and start-up problems
Check if the battery has power. If yes, contact customer support if it cannot be started normally.
4. SW update issues
Follow the instructions in the user manual to update the firmware. If the firmware update fails, restart all the devices and try again. If the problem persists, contact customer support.
5. Shutdown and power-off problems
Contact customer support.
6. How to detect careless handling or storage in unsafe conditions
Contact customer support.

» 9.5 Risk and Warnings

When the drone detects a risk after powering on, there will be a warning prompt on Potensic Eve. Pay attention to the list of situations below.

1. If the drone status is not suitable for takeoff.
2. If the compass experiences interference and needs to be calibrated.
3. Follow the on-screen instructions when prompted.

» 9.6 Disposal



Observe the local regulations related to electronic devices when disposing of the drone and remote controller.

Battery Disposal

Dispose of the batteries in specific recycling containers only after a complete discharge. DO NOT dispose of the batteries in regular trash containers. Strictly follow the local regulations regarding the disposal and recycling of batteries.

Dispose of a battery immediately if it cannot be powered on after over-discharging.

If the Smart Battery cannot be fully discharged, contact a professional battery disposal/recycling agency for further assistance.

» 9.7 C0 Certification

ATOM 2 (DSDR23A) is compliant with C0 certification requirements.

Model:	DSDR23A
UAS Class:	C0
Maximum Take-Off Mass (MTOM):	245 g
Maximum Propeller speed:	16800RPM

MTOM Statement

The MTOM of ATOM 2 (Model DSDR23A), including the Smart Battery, Propellers, and a microSD card, is 245 g to comply with C0 requirements.

Users must follow the instructions below to comply with the MTOM requirements for each model:

1. DO NOT add any payload to the drone except the items listed in the List of Items including qualified accessories section.
2. DO NOT use any non-qualified replacement parts, such as smart flight batteries or propellers, etc.
3. DO NOT retrofit the drone.

List of Items, including qualified accessories

For C0

Item	Model Number	Dimensions	Weight
Propellers	DSDR23A-PPS	119.4×63.8 mm (Diameter×Thread Pitch)	0.65 g (each piece)
Smart Battery	DSBT02B	83.6×42.5×34.6 mm	Approx. 84 g
microSD Card*	N/A	15×11×1.0 mm	Approx. 0.3 g

* Not included in the original package.

List of Spare and Replacement Parts

For C0

1. ATOM 2 Propellers
2. ATOM 2 Smart Battery

Remote Controller Warnings

Model: DSRC23A

If the remote controller is disconnected from the drone, the Potensic Eve App will prompt an on-screen note, and the drone will perform the preset behavior when the remote controller signal is lost. The remote controller will shut down automatically after 20 minutes of no operation.

- Avoid interference between the remote controller and other wireless equipment. Make sure to turn off the Wi-Fi on nearby mobile devices. Land the drone as soon as possible if there is interference.
- DO NOT operate the drone if lighting conditions are too bright or dark when using a mobile phone to monitor the flight. Users are responsible for correctly adjusting the display brightness when using the monitor in direct sunlight during flight operation.
- Release the control sticks or press the Return to Home (RTH) Button if an unexpected operation occurs.

Precaution List

Below is the list of mechanical and operational precautions for ATOM 2:

1. In emergency situations, the propellers can be stopped by performing a combination stick command. For detailed information, please refer to Section 6.3.4 Emergency Propeller Stop Mid-Flight.
2. Return to Home (RTH) function. For detailed information, please refer to Section 8.8 Return to Home (RTH).
3. Downward Vision System. For detailed information, please refer to Section 5.2 Downward Vision System.
4. The GEO Zone function will restrict or prohibit flight operations in specific areas such as Restricted Zones, Altitude Zones, etc., ensuring users can safely and legally operate the drone. For detailed information, please refer to Section 8.3 GEO Zone.

EASA Notice

Make sure to read the Drone Information Notices document included in the package before use.

Visit the link below for more EASA notice information on traceability.

<https://www.easa.europa.eu/en/document-library/general-publications/drones-information-notices>

Original Instructions

This manual is provided by Shenzhen Potensic Intelligent Co., Ltd and the content is subject to change.

Address: 7/F, Building A5, Nanshan Intelligent Park, Nanshan District, Shenzhen, CN

» 9.8 Risk categories and assessment

1. Please choose an open, unobstructed environment for takeoff, away from crowds, obstacles, and water surfaces. During flight, maintain visual line-of-sight and avoid flying over crowds.
2. The maximum flight altitude of the drone is 120 m. Please strictly follow local laws and regulations.
3. The drone does not support the installation of third-party accessories or additional loads to avoid affecting the drone's performance.
4. Before flying, ensure the battery is properly inserted into the drone, and the battery buckle is securely in place.
5. Before flying, please enter the relevant information in Potensic Eve App > Settings > Safety > Remote ID, in accordance with local regulations, and ensure the Remote ID feature is enabled.
6. Before takeoff, ensure that the Flight Safety Data is updated to the latest version.
7. The software in the drone system has passed strict security certification and uses advanced encryption and anti-tamper mechanisms. There is high security during the download of videos, photos, and firmware upgrades.
8. Do not use this product in strong magnetic fields or near large metal objects, such as metal mines, parking lots, large steel-reinforced concrete buildings, high-voltage cables, etc.
9. Do not disassemble or modify this product. Always use the officially recommended original accessories. Using non-original accessories may pose safety risks to the drone's safe operation.

Risk categories and assessment					
(Scoring 1-5, level = Likelihood x Severity, 1-4 low risk, 5-10 medium risk, 12-25 high risk)					
Risks	Likelihood	Severity	Level	Mitigation	Robustness
Exceed maximum takeoff weight	1	2	2	MTOM Declaration	Med
Maintain a safe distance from mission-related crowds	2	2	4	Add warnings in the manual; minimize flying time over crowds	Med
Fly over crowds of people	1	4	4	Add warnings in the manual; pre-flight checklist need to be confirmed	Med
BVLOS during flight	2	2	4	Add warnings in the manual; make sure that the flight area is free of any obstacles before flying.	Med
Exceed the 120 m height limit during flight	1	3	3	Add instructions in the manual; enable the altitude limit before flying, or the built-in altitude limit	High
Carry hazardous items during flight	1	4	4	Add description of prohibiting payload with hazardous items; add warnings in the manual	Med
Items dropping from the drone mid-flight	1	3	3	Add description of checking all parts are fastened before takeoff; add warning in the manual to prohibit carrying items prone to falling mid-flight	Med
Pilot is under 16 years of age	1	2	2	Add label warning on the product package	Med
Pilot is not familiar with the manual	2	2	4	Add label warning on the product package	Low
Remote ID is not enabled	2	2	4	Add instructions of enabling RID broadcast before takeoff, or enabling it by default.	Med
Fail to update flight safety data, resulting in flying into Restricted Zones	1	3	3	Add instructions of updating flight safety data before takeoff	Med
Risks during data exchange (downloading videos, photos, upgrading software) between the UAS and external devices	1	2	2	Add description of the protocols for transferring data with a high level of security in the manual.	High
Risks during software upgrades for UAS	1	1	1	Add description of the protocols for upgrading software with limited access or remote upgrades with a high level of security in the manual.	High
Risks of using the drone in strong magnetic field locations	2	2	4	Add warning against the use of the product in strong magnetic fields.	High
Illegal modification of drones leading to risk of malfunction	2	2	4	Add warning against disassembling or modifying the product except for officially recommended accessories in the manual.	High

Likelihood \ Severity	1	2	3	4	5
1	1	2	3	4	5
2	2	4	6	8	10
3	3	6	9	12	15
4	4	8	12	16	20
5	5	10	15	20	25

» 9.9 Drone Pilot Information Notice



This drone is an aircraft. Aviation law applies.

As a drone pilot, you are responsible for flying your drone safely.

Before flying, as a drone pilot, you must

- ✓ make sure the drone owner is registered at his or her national authority (unless already registered)
- ✓ make sure the owner registration number is displayed on the drone
- ✓ read and follow the manufacturer's instructions



Check how to register and where you are allowed to fly:

www.easa.europa.eu/drones/NAA



DO



Make sure you are adequately insured.



Check for no-fly zones and any limitations in the area where you want to fly.



Keep the drone in sight at all times.



Maintain a safe distance between the drone and people, animals and other aircraft.



Inform your national aviation authority immediately if your drone is involved in an accident that results in a serious or fatal injury to a person, or that affects a manned aircraft.



Operate your drone within the limits defined in the manufacturer's instructions.

DO NOT



Do not fly over large group of people.



Do not fly higher than 120 m from the ground.



Do not fly near aircraft & in the proximity of airports, helipads or where an emergency response effort is ongoing.



Do not infringe other people's privacy.



Do not record intentionally or publish photographs, videos or audio recordings of people without their permission.



Do not use the drone to carry dangerous goods or to drop material.



Do not modify your drone. Only software uploads recommended by the drone manufacturer are allowed.

» 9.10 EU Compliance Notice

EU Compliance Statement: Shenzhen Potensic Intelligent Co., Ltd. declares that the device ATOM 2 complies with the essential requirements and other relevant provisions of Directive 2014/53/EU and Regulation (EU) 2019/945.

The EU Declaration of Conformity (DoC) is available for download on our official website:

<https://www.potensic.com/downloads.html> (Go to the Download Center, select "ATOM 2", and download the EU Declaration of Conformity from the ATOM 2 DoC file list.)

EU Representative Address: Ocean Trading GmbH, Anhalter Str.10, 10963, Berlin, Germany

E-mail: ear@oceantrading.de

Tel/Mobile: 0049-30/25758899

Changes or modifications not expressly approved by the party responsible for compliance could void the user's authority to operate the equipment.

This device complies with Part 15 of the FCC Rules. Operation is subject to the following two conditions:

(1) This device may not cause harmful interference, and (2) This device must accept any interference received, including interference that may cause undesired operation.

Note: This equipment has been tested and found to comply with the limits for a Class B digital device, pursuant to Part 15 of the FCC Rules. These limits are designed to provide reasonable protection against harmful interference in a residential installation. This equipment generates, uses, and can radiate radio frequency energy, and if not installed and used in accordance with the instructions, may cause harmful interference to radio communications. However, there is no guarantee that interference will not occur in a particular installation. If this equipment does cause harmful interference to radio or television reception, which can be determined by turning the equipment off and on, the user is encouraged to try to correct the interference by one or more of the following measures:

- Reorient or relocate the receiving antenna.
- Increase the separation between the equipment and receiver.
- Connect the equipment into an outlet on a circuit different from that to which the receiver is connected.
- Consult the dealer or an experienced radio/TV technician for help.

This equipment complies with FCC radiation exposure limits set forth for an uncontrolled environment. This equipment should be installed and operated with a minimum distance of 20 cm between the radiator & your body. This transmitter must not be co-located or operating in conjunction with any other antenna or transmitter.

IC Statement:

This device contains licence-exempt transmitter(s)/receiver(s) that comply with Innovation, Science and Economic Development Canada's licence-exempt RSS(s). Operation is subject to the following two conditions:

(1) This device may not cause interference.

(2) This device must accept any interference, including interference that may cause undesired operation of the device.

L'émetteur/récepteur exempt de licence contenu dans le présent appareil est conforme aux CNR d'Innovation, Sciences et Développement économique Canada applicables aux appareils radio exempts de licence. L'exploitation est autorisée aux deux conditions suivantes:

(1) L'appareil ne doit pas produire de brouillage;

(2) L'appareil doit accepter tout brouillage radioélectrique subi, même si le brouillage est susceptible d'en compromettre le fonctionnement.

ISED Radio Frequency Exposure Statement:

The device has been evaluated to meet general RF exposure requirements. The device can be used in mobile exposure conditions. The min separation distance is 20 cm.

ISED Déclaration d'exposition aux radiofréquences:

L'appareil a été évalué pour répondre aux exigences générales en matière d'exposition aux RF. L'appareil peut être utilisé dans des conditions d'exposition mobiles. La distance de séparation minimale est de 20 cm.

Operation of this device is restricted to indoor use only. (5150-5250MHz)

Le fonctionnement de cet appareil est limité à une utilisation en intérieur uniquement. (5150-5250MHz)

For Canada: The frequency stability of all transmission frequencies of U-NII-1, U-NII-3 meets the requirements of RSS-Gen Issue 5, Section 6.11, and the manufacturer states that their transmissions remain within the U-NII-1, U-NII-3 bands.

Pour le Canada: La stabilité de fréquence de toutes les fréquences de transmission U-NII-1, U-NII-3 répond aux exigences de la norme CNR-Gen, édition 5, section 6.11, et le fabricant déclare que leurs transmissions restent dans les bandes U-NII-1, U-NII-3.

EU Conformity Statement:



This product and - if applicable - the supplied accessories too are marked with "CE" and comply therefore with the applicable harmonized European standards listed under the RED Directive 2014/53/EU, the RoHS Directive 2011/65/EU and Amendment (EU)2015/863.



2012/19/EU (WEEE directive): Products marked with this symbol cannot be disposed of as unsorted municipal waste in the European Union. For proper recycling, return this product to your local supplier upon the purchase of equivalent new equipment, or dispose of it at designated collection points. For more information see: www.recyclethis.info



2023/1542/EU (battery directive): This product contains a battery that cannot be disposed of as unsorted municipal waste in the European Union. See the product documentation for specific battery information. The battery is marked with this symbol, which may include lettering to indicate cadmium (Cd), lead (Pb), or mercury (Hg). For proper recycling, return the battery to your supplier or to a designated collection point. For more information see: www.recyclethis.info

Potensic ATOM 2 Drone/飞行器

Model/型号: DSDR23A

FCC ID: 2BK8B-DSDR23A

IC ID: 32661-DSDR23A

CMIIT ID: 25Z449G85170

Nominal Voltage/标称电压: 7.7 V

Max Charge Voltage/充电限制电压: 8.8 V

Rated Capacity/额定容量: 2230 mAh

Rated Energy/额定能量: 17.18 Wh

Input/输入: 5 V \equiv 3 A



Potensic PT 1 Remote Controller/遥控器

Model/型号: DSRC23A

FCC ID: 2BK8B-DSRC23A

IC ID: 32661-DSRC23A

CMIIT ID: 25Z449G8U867

Nominal Voltage/标称电压: 3.6 V

Max Charge Voltage/充电限制电压: 4.2 V

Rated Capacity/额定容量: 5200 mAh

Rated Energy/额定能量: 18.72 Wh

Input/输入: 9 V \equiv 2 A



This device complies with Part 15 of the FCC Rules. Operation is subject to the following two conditions: (1) This device may not cause harmful interference, and (2) This device must accept any interference received, including interference that may cause undesired operation.

EC REP Ocean Trading GmbH Anhalter Str.10, 10963, Berlin, Germany
E-mail: ear@oceantesting.de
Tel/Mobile: 0049-30/25758899

UK REP OCEAN SUPPORT LTD Amber, Office 119, Luminous House 300 South Row, Milton keynes, MK9 2FR
E-mail: info@topouxun.com



Importer: Potensic SAS

EU contact address: 7 Place de l'Hôtel de Ville, 93600, Aulnay-sous-Bois Email: eu@potensic.com

Manufacturer/制造商: Shenzhen Potensic Intelligent Co., Ltd./深圳市博坦智能科技有限公司

Address/地址: 7/F, Building A5, Nanshan Intelligent Park, Nanshan District, Shenzhen, CN/深圳市南山区南山智园 A5 栋 7 层

Web: <https://www.potensic.com>

Email: support@potensic.com

MADE IN CHINA



DANGER! Only suitable for ages 16+
GEFAHR! Nur für Personen ab 16 Jahren geeignet
PERICOLO! Adatto solo a persone di età superiore ai 16 anni
DANGER! Convient uniquement aux personnes âgées de plus de 16 ans
PELIGRO! Solo apto para mayores de 16 años
GEVAAR! Alleen geschikt voor personen van 16 jaar en ouder
VARING! Endast lämpligt för personer på 16 år eller äldre
¡PELIGRO! Adecuado apenas para mayores de 16 años
警告! 本产品仅供 16 岁及以上人士使用
警告! 本产品仅供 16 歲及以上人士使用
警告! この製品の対象年齢は 16 歳以上です
警告! 본 제품은 16세 미만 사용 금지



Warning! High-speed spinning propellers can cause serious injury!
Warnung! Schnell drehende Propeller können schwere Verletzungen verursachen!
ATTENZIONE! Le eliche che girano ad alta velocità possono causare gravi lesioni!
ATTENTION! Les hélices tournant à grande vitesse peuvent provoquer des blessures graves!
¡ADVERTENCIA! Las hélices girando a alta velocidad pueden causar lesiones graves!
WAARSCHUWING! Snel ronddraaiende propellers kunnen ernstig letsel veroorzaken!
VARING! Högfrekventa snurrande propeller kan orsaka allvarliga skador!
ATENÇÃO! Hélices girando em alta velocidade podem causar ferimentos graves!
警告! 高速運轉的螺旋槳可能造成嚴重傷害!
警告! 高速運轉的螺旋槳可能造成嚴重傷害!
警告! 高速で回転しているプロペラを触ると重大な傷害を引き起こすリスクがあります!
경고! 고속으로 회전하는 프로펠러는 심각한 부상을 초래할 수 있습니다!



CAUTION! Please read the User Manual and relevant flight safety guidelines carefully before using the drone.
ACHTUNG! Bitte lesen Sie vor der Verwendung der Drohne sorgfältig das Benutzerhandbuch sowie die entsprechenden Flugsicherheitsrichtlinien.
ATTENZIONE! Prima di utilizzare il drone, leggere attentamente il Manuale d'uso e le linee guida sulla sicurezza del volo.
ATTENTION! Veuillez lire attentivement le manuel de l'utilisateur et les consignes de sécurité relatives au vol avant d'utiliser le drone.
PRECAUCIÓN! Lea atentamente el Manual de Usuario y las pautas de seguridad de vuelo antes de usar el drone.
LET OP! Lees de Gebruikershandleiding en de relevante veiligheidsrichtlijnen voor vluchten grondig door voordat u de drone gebruikt.
VARING! Läs användarhandboken och relevanta flygsäkerhetsriktlinjer noggrann innan du använder drönaren.
CUIDADO! Leia atentamente o Manual do Usuário e as diretrizes de segurança de voo relevantes antes de usar o drone.
注意! 使用飞行器之前, 请熟读用户手册及相关飞行安全指南。
注意! 使用飞行器之前, 请熟读使用者手册及相關飛行安全指南。
注意! ドローンを使用する前に、取扱説明書および関連する飛行安全ガイドをよくお読みください。
주의! 드론을 사용하기 전에 사용자 설명서와 관련 비행 안전 지침을 숙독하시기 바랍니다.

Support

Country/Region: United States Continental (Excluding Puerto Rico, Guam, Saipan, and the Virgin Islands)

Tel: +1 833 549 7772

Service Time: Sat-Mon 7:00 - 22:00 (EST/EDT) Tue-Fri 9:00 - 18:00 (EST/EDT)

If you have any questions or suggestions about this document, please contact us: support@potensic.com.

Potensic is a trademark of Shenzhen Potensic Intelligent Co., Ltd.

Copyright © 2025 Potensic