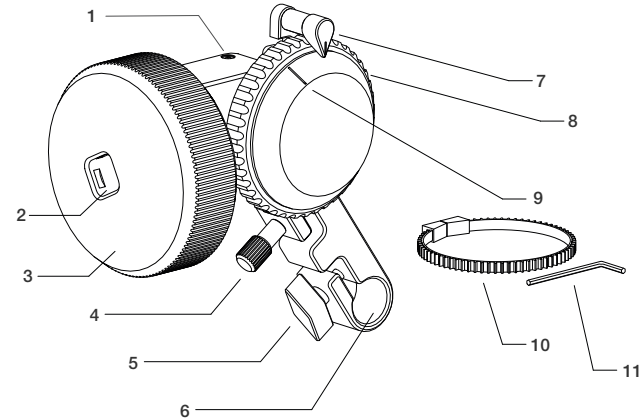

TABLE OF CONTENTS

1. WHAT'S IN THE BOX & THE BASICS
2. ATTACHING LENS GEAR
3. MOUNTING YOUR FOCUSONE
4. SETTING THE CONTROL WHEEL
5. MARKING A FOCUS POINT
6. ADJUSTING THE GEAR PLAY

1. WHAT'S IN THE BOX & THE BASICS



- | | |
|--|------------------------|
| 1. Gear play adjustment screw | 6. 15mm rod clamp |
| 2. Accessory port | 7. Focus point marker |
| 3. Control wheel | 8. 0.8 pitch gear |
| 4. Control wheel angle adjustment screw (Silver thumb screw) | 9. Marking disc |
| 5. Thumb screw | 10. Lens gear |
| | 11. 2.5mm allen wrench |

2. ATTACHING THE LENS GEAR

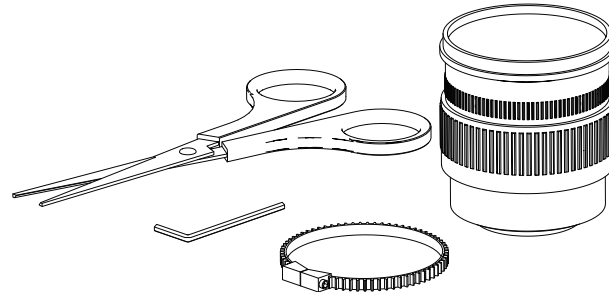

If you have a video lens, you don't need to attach Lens Gear and may skip this step.
If you don't have 0.8 pitch on your lens, attach Lens Gear on your lens.

 A detailed video explaining how to attach the lens gear can be found at: manuals.edelkrone.com

3. MOUNTING YOUR FOCUSONE

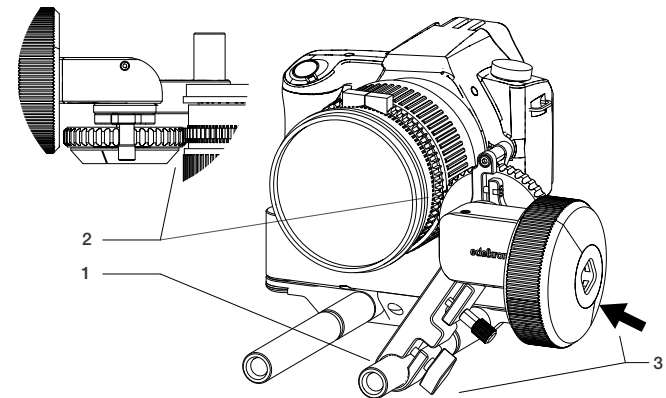

1. Attach FocusONE to the 15 mm rod.
2. Make sure that the gear on your FocusONE is aligned with the gear on your lens.
3. While pushing your FocusONE towards to your lens, tighten the thumb screw.

 Make sure there is no gap between gears to increase precision.

 A detailed video explaining the mounting process can be found at: manuals.edelkrone.com

4. SETTING THE CONTROL WHEEL

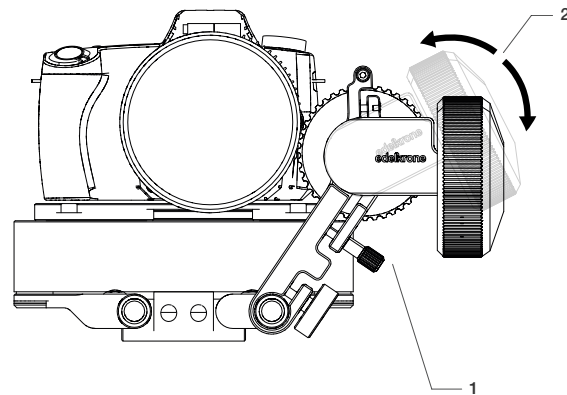

The control wheel can be adjusted to fit your shooting style.

1. Loosen the silver thumb screw.
2. Set your angle and tighten the silver thumb screw.

 A detailed video explaining the control wheel can be found at: manuals.edelkrone.com

5. MARKING YOUR FOCUS POINT

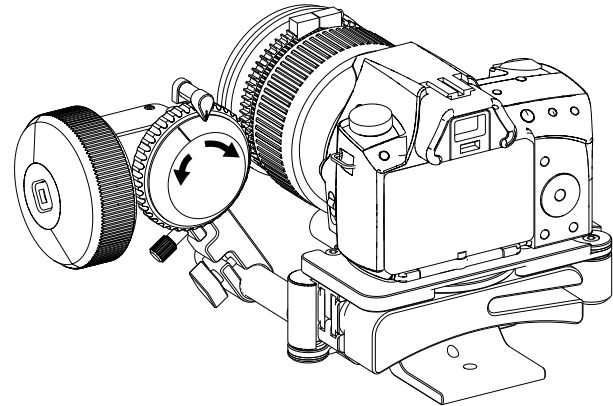

The best way to use your FocusONE is finding your focus point with the control wheel and aligning the disc with the focus point marker as precisely as possible with your hand. This means you marked your focus point. Now you can leave and return to your focus point as you like.

 A detailed video explaining the marking your point process can be found at: manuals.edelkrone.com

6. ADJUSTING THE GEAR PLAY

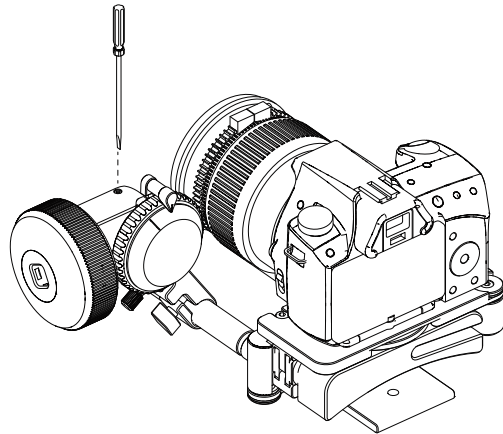

You can easily adjust the gear play with a small flat head screw driver. While checking the play from the control wheel, tighten the screw to a point that is still comfortable to control the wheel.

 A detailed video explaining how to adjust the gear play can be found at: manuals.edelkrone.com

DISCLAIMER

edelkrone cannot be held responsible for damage caused by improper use or modification of the product.

 For more information and tips on FocusONE, please watch the user's manual videos at: manuals.edelkrone.com

FOCUSONE USER'S MANUAL

Before operating your edelkrone,
please watch the user's manual video from the link below

manuals.edelkrone.com